

www.cycarbide.com

**CYCT**  
长鹰硬科

昆山长鹰硬质材料科技股份有限公司  
CY CARBIDE MFG. CO., LTD.

地址：江苏省 昆山市 玉城北路67号  
服务热线：400-863-2919

Add: No. 67, Yucheng Road (N.), Kunshan, Jiangsu, China  
Post Code: 215300  
Tel: +86 400 863 2919



扫一扫·了解更多  
Scan the QR code  
to learn more

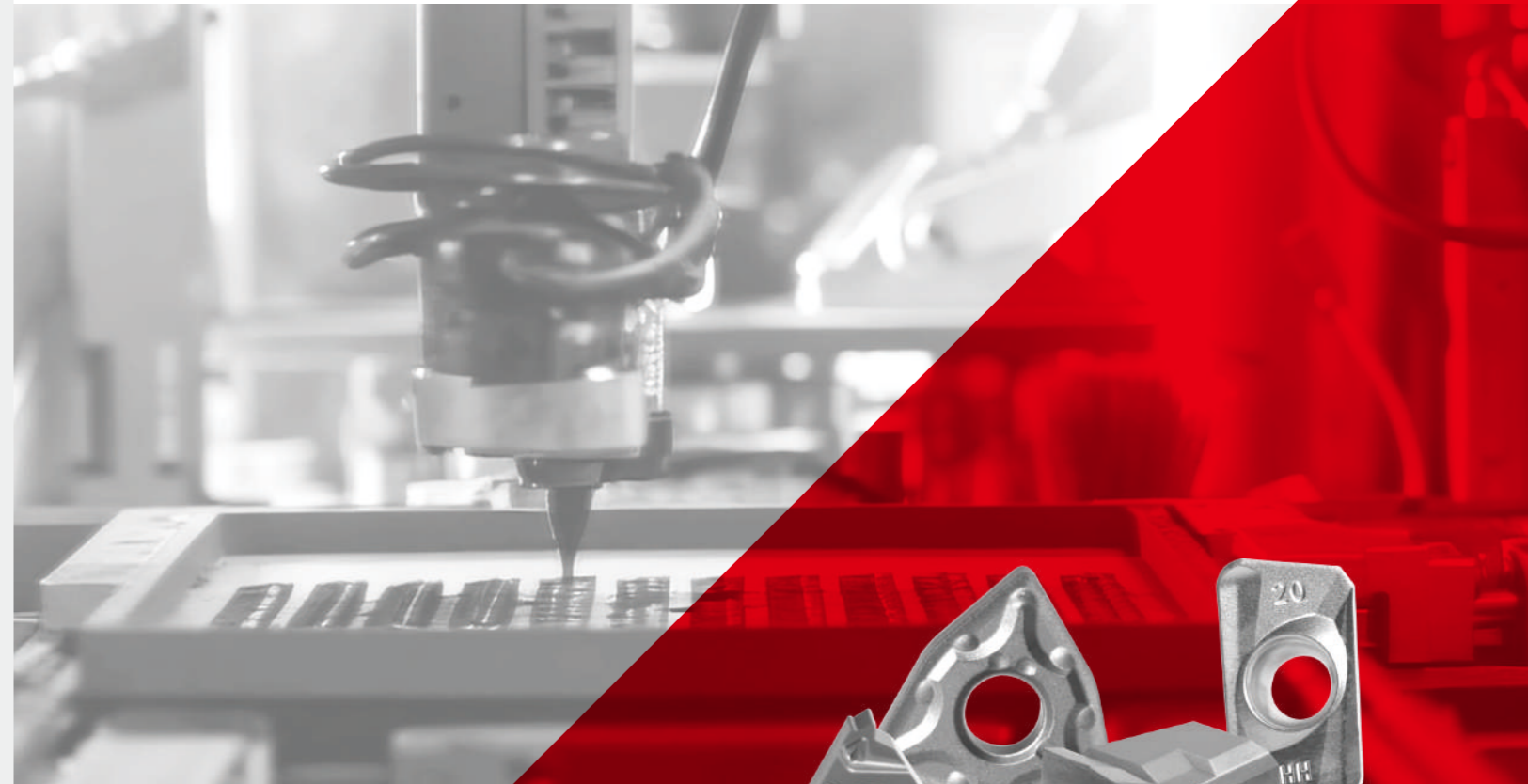

**硬质合金刀片基体**  
Carbide Insert Blanks

# 专注发展为 全球硬质材料及应用科技的引领者

Dedicated to becoming a global leader in hard materials and applied technology

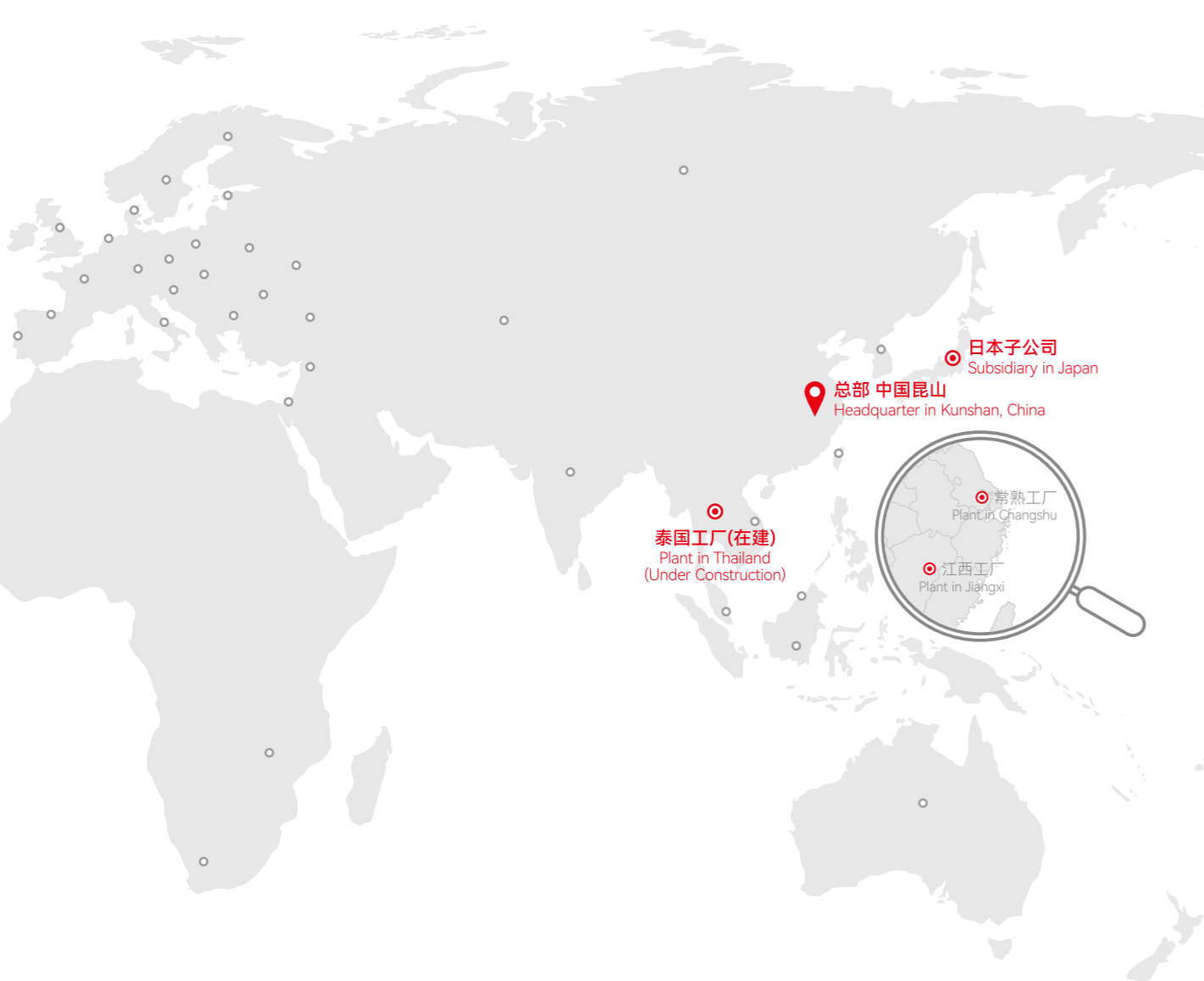

## 目录

### Contents

关于长鹰 About Us	01
发展历程 Enterprise History	03
研发中心 R&D Center	05
分析检测中心 Analysis & Testing Center	06
生产工艺流程 Manufacturing Process	07
常用基体刀片牌号 Common Insert Blank Grades	11
应用推荐 Application Recommendations	12

<b>A</b> 皇冠钻 Crown Drills	
通用皇冠钻基体 Standard Crown Drill Blanks	14

<b>B</b> 切槽刀 Grooving Inserts	
通用切槽刀基体 Standard Parting & Grooving Insert Blanks	16

<b>C</b> 车削刀片 Turning Inserts	
车削刀片命名规则 Naming Rules for Turning Inserts	19
负角车削刀片 (不锈钢加工) Negative Turning Inserts (Stainless Steel)	21
负角车削刀片 (钢件加工) Negative Turning Inserts (Steel)	22
负角车削刀片 (铸铁加工) Negative Turning Inserts (Cast Iron)	23
正角车削刀片 (不锈钢加工) Positive Turning Inserts (Stainless Steel)	24
小零件加工刀片 Turning Inserts for Small Parts	25

<b>D</b> 铣削刀片 Milling Inserts	
铣削刀片命名规则 Naming Rules for Milling Inserts	27
通用铣削刀片 Standard Milling Inserts	29

<b>E</b> 钻削刀片 Drilling Inserts	
通用钻削刀片 Standard Drilling Inserts	35

<b>F</b> 螺纹刀片 Threading Inserts	
不锈钢螺纹刀片 Threading Inserts for Stainless Steel	37

<b>G</b> 通用技术信息 General Technical Information	
刀具规格选用方法 Tool Specification Selection Guide	39
硬质合金产品安全标准 Safety Standards for Cemented Carbide Products	40

 **20<sup>+</sup>** Since Foundation  
成立时间

 **800<sup>+</sup>** Employees  
员工

 **4** Plants  
工厂

 **2500** Annual Capacity  
年产能

 **100<sup>+</sup>** Grades 材质  
**100,000<sup>+</sup>** Specs 产品规格

 **50<sup>+</sup>** Countries/Regions  
出口国家/地区

## 关于长鹰 About Us

昆山长鹰硬质材料科技股份有限公司专业生产硬质合金基体刀片和皇冠钻基体，数控刀片产品品牌“**CYCT**长鹰硬科”。

公司是高新技术企业、国家级专精特新“小巨人”企业，具有20多年优质硬质合金材料研发、生产、营销和服务经验。公司生产的稳定高精度高效数控刀片，比肩日韩、完美替代欧美同类产品，用于加工P类、M类、K类、S类、N类、H类等被加工材料；针对性牌号和型号分别适合于车削、铣削、钻削等加工方式；广泛应用于精密模具制造、汽车零部件、通用机械、清洁能源、3C、航空航天、船舶、轨道交通、重型装备等行业。

公司聚集了众多国内外资深技术专家，包含基体材质、刀片设计、模具制造、精密成型、化学涂层和物理涂层，以及刀具应用等专业领域。他们具有深厚的理论功底和丰富的实践经验。公司拥有省级企业工程技术研究中心、省级企业技术中心、博士后科研工作站等研发机构。公司拥有数十项授权专利，其中发明专利10余项。

CY CARBIDE MFG. CO. LTD., established in 2003, is a professional manufacturer and exporter of cemented carbide and cermet materials. CYC delivers globally high performance standard and non-standard products, that meet the most challenging demands from various applications including metalworking, mining, construction, oil & gas, die & mold, and woodworking.

Based on 20 years hard materials manufacturing experience, CYC set up a new brand "CYCT" for inserts R&D, and manufacturing. Our stable, effective and precision inserts are widely used for machining P, M, K, S, N and H workpiece. Specially designed grades and types are suitable for turning, milling and drilling. Products are extensively applied in the industry of molds, automotive accessories, general machine, clean energy, 3C, aerospace, shipping, railway transportation, and heavy equipment etc.



# 发展历程 Enterprise History

**1st**

江苏昆山  
城北工厂  
Carbide Factory  
in Kunshan



长野硬质合金



ISO9001

公司通过  
质量管理体系TUV  
Certified by TUV



**2nd**

江西  
抚州工厂  
Carbide Factory  
in Jiangxi



**3rd**

江苏昆山  
城南工厂  
Carbide Factory  
in Kunshan



日本  
设立长鹰子公司  
Subsidiary in Japan

东莞  
成立华南办事处  
South China office

更名  
昆山长鹰硬质材料  
科技股份有限公司  
Renamed to CY  
Carbide Mfg. Co., Ltd.

成立  
超硬材料事业部  
Establish Ultra-Hard  
Materials Division

**4th**

数控刀片  
常熟工厂  
Carbide Inserts Factory  
Started Operation



国家级  
专精特新“小巨人”  
National-level  
Specialized and  
Sophisticated  
“Little Giant”  
Enterprise

江苏省  
绿色工厂称号  
Title of Jiangsu  
Provincial Green  
Factory

江苏省认定  
“外国专家工作室”  
Province certified  
“Foreign Expert  
Studio”

中国钨协  
“中国硬质合金  
行业成长标杆  
企业”称号  
“Growth Benchmark  
Enterprise in China's  
Carbide Industry”  
by China Tungsten  
Association

2003

2010

2014

2015

2017

2018

2019

2020

2021

2022

2023

2024

2025

**200<sup>+</sup>**

吨年产量  
Tons Output

**500<sup>+</sup>**

吨年产量  
Tons Output

**1000<sup>+</sup>**

吨年产量  
Tons Output

**1200<sup>+</sup>**

吨年产量  
Tons Output

**1700<sup>+</sup>**

吨年产量  
Tons Output

**2000<sup>+</sup>**

吨年产量  
Tons Output

### 研发中心 R&D Center



#### 研发团队 R&D Team

20多年的硬质合金研发和制造经验，公司拥有国内外行业专家、高级工程师组成研发团队，具备业内一流的研发能力。

With over 20 years of experience in Carbide materials R&D and manufacturing, We have a strong R&D team consisting of industry experts, senior engineers, possessing first-class R&D capabilities in the industry.



#### 研发设备 R&D Equipment

公司配备全系列国内外先进研发设备，独立研发品生产线及刀具切削测试中心，为新产品研发提供坚实硬件基础。

Our factory is well equipped with international advanced R&D facilities, which provide a solid foundation for new product development.



#### 高校合作 Cooperation with Universities

公司始终重视产学研结合，积极搭建外部合作创新平台，与中南大学、东北大学、湖南工业大学等多所知名高校建立了“研发-生产-应用”产学研用合作系统。

We always prioritize the cooperation between manufacturing and research, and have built up an innovation platform with universities, such as Central South University, Northeastern University, Hunan University of Technology and so on.

### 分析检测中心 Analysis & Testing Center

▶ 日本电子JEOL  
扫描电镜  
SEM tester  
(JEOL-Japan)



▶ 荷兰铁诺维氏硬度计  
Innovatest Hardness Tester



▶ 海克斯康三坐标测量仪  
Hexagon CMM

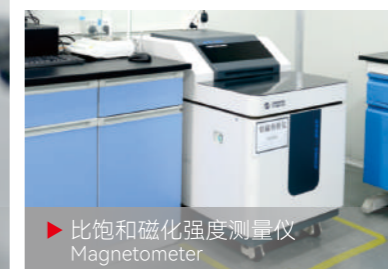

▶ 比饱和磁化强度测量仪  
Magnetometer

含碳化钨、混合料、硬质合金毛坯以及成品化学元素定量检测，微观结构分析，比饱和磁化强度、矫顽磁力等物理性能检测;设备齐全，方法专业，为研发及生产提供有效数据支撑。(相关设备:日本电子电镜扫描仪SEM,德国莱卡金相显微镜及其相应的金相定量分析软件、万能试验机、三坐标机等)。

We have all the test facilities for Tungsten Carbide Powder, RTP, chemical element composition of finished goods, and micro structure analysis, which provide an effective database for R&D and manufacturing (including Japan SEM tester, Germany Leica metallographic microscope and micro structure analysis software, strength test machine, and three-coordinates measuring machine, etc.)

生产工艺流程  
Manufacturing Process

01 材质设计  
Material Design



02 混合料球磨  
Mixed Material Ball Milling



03 喷雾制粒  
Spray Granulation



04 模具制造  
Mold Manufacturing

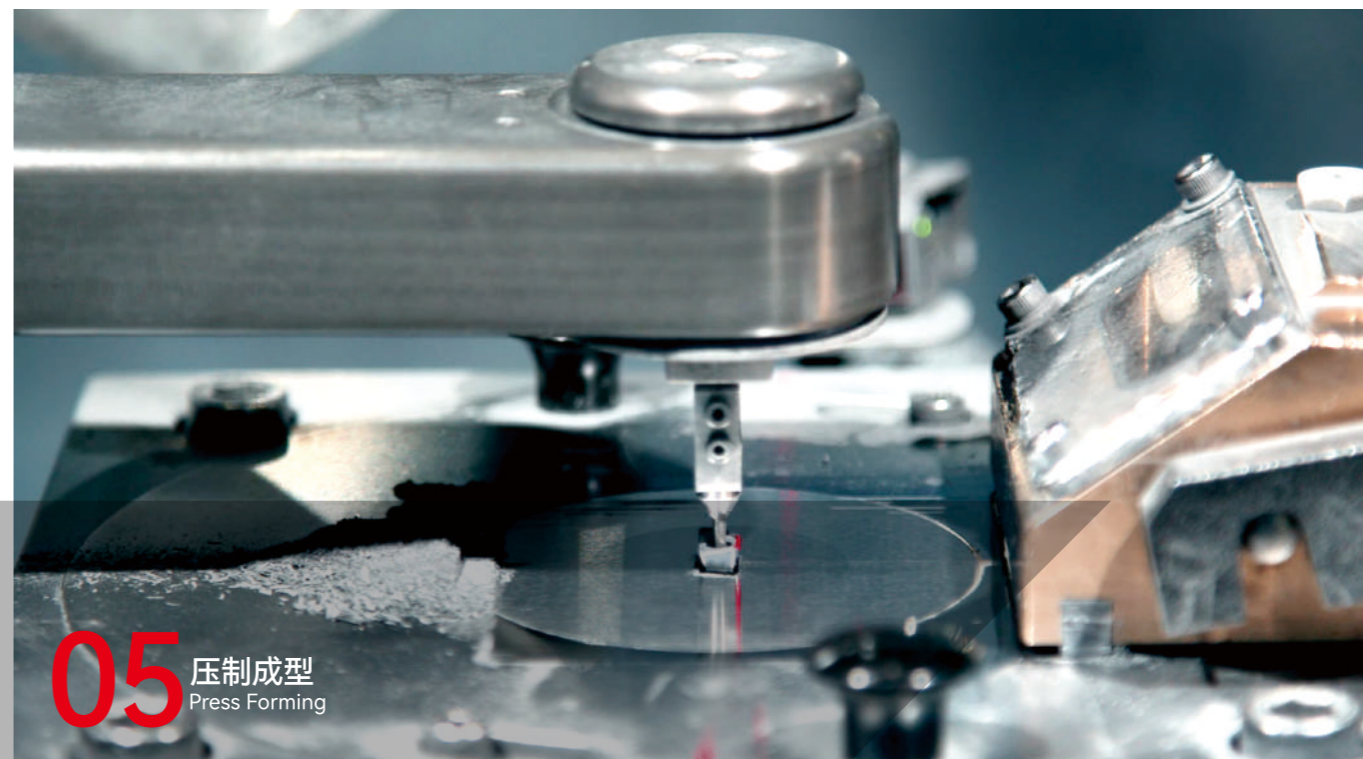

05 压制成型  
Press Forming

# 06 加压烧结 Pressure Sintering

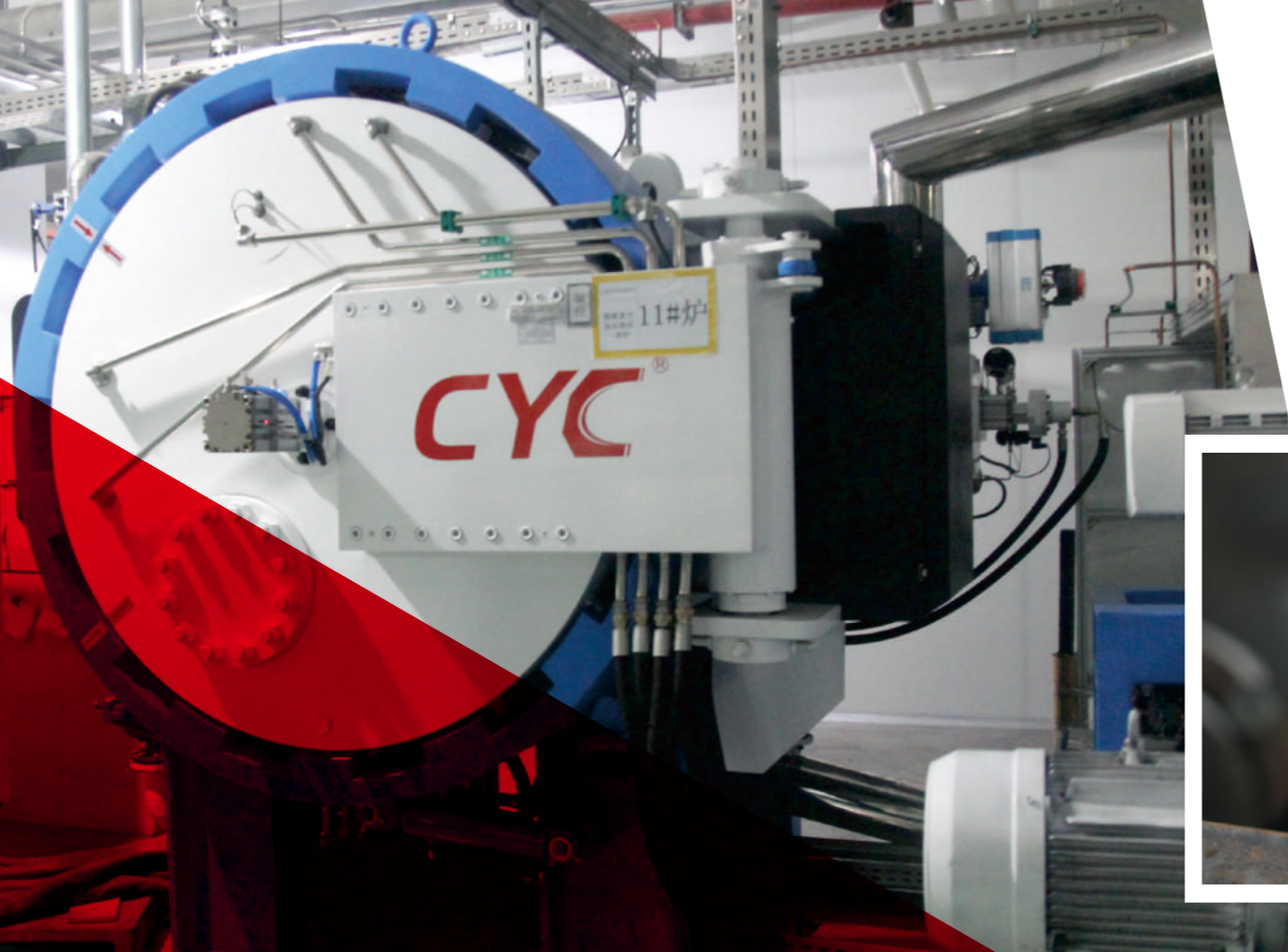

# 07 研磨加工 Abrasive Machining

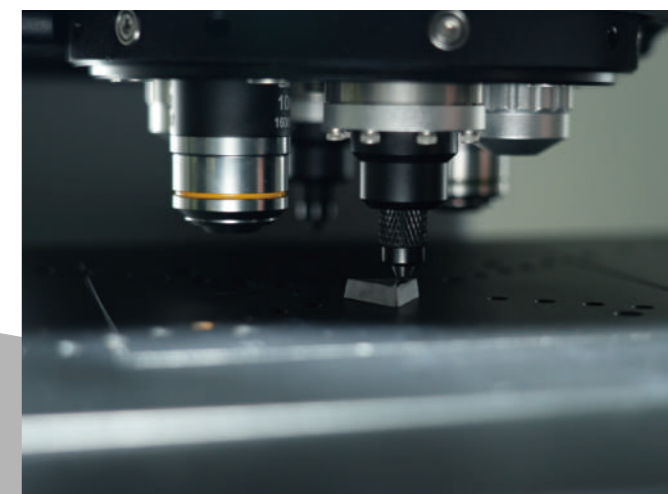
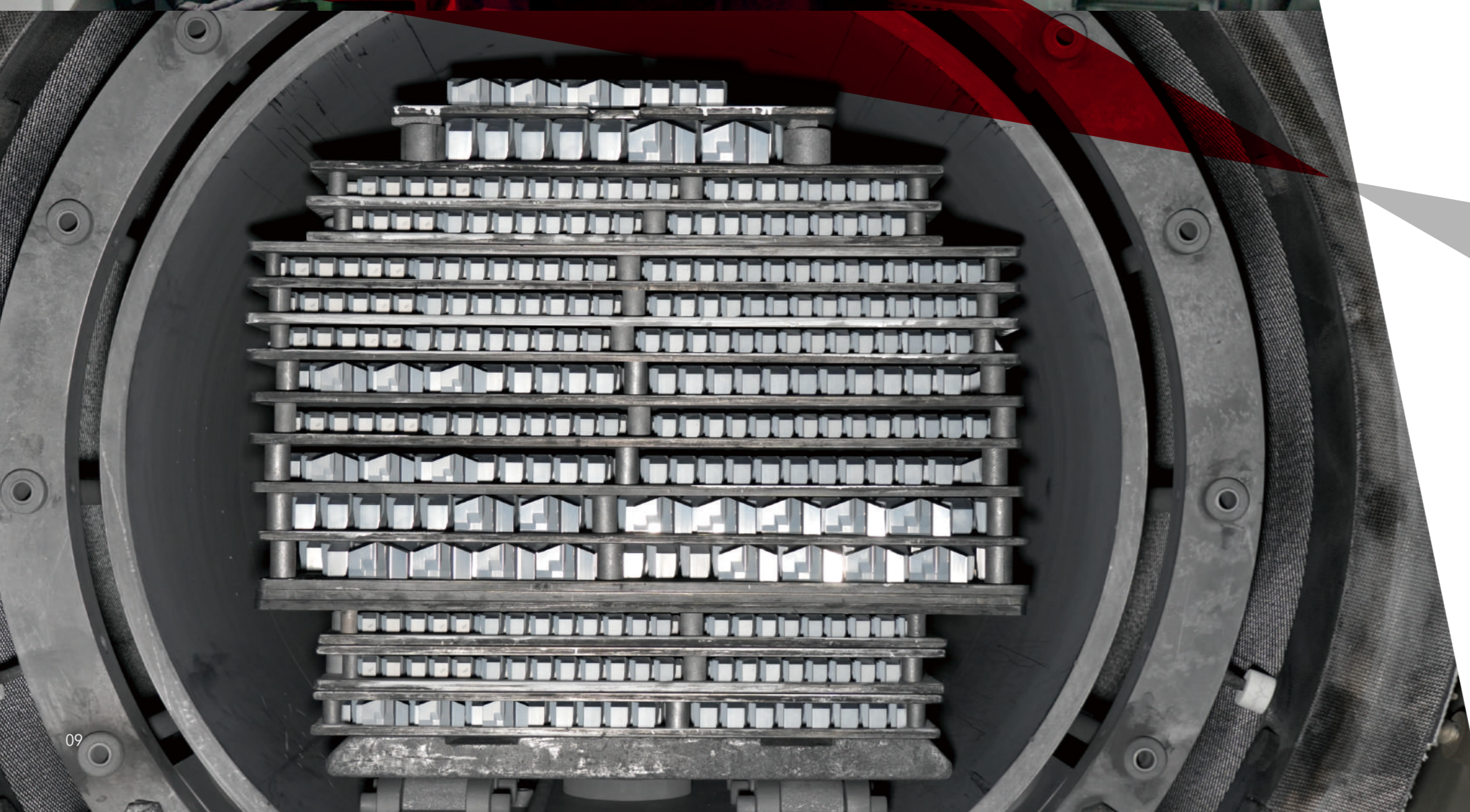

# 08 检验 Test

## 常用基体刀片牌号

## Common Insert Blank Grades

牌号 Grade	Wc%	Co%	颗粒度 Grain Size	硬度 Hardness	涂层 Coating	推荐加工方式 Typical Applications
MH12S	88	12	0.8	91.6	PVD	适用于钢件、不锈钢、钛合金的铣削加工 Suitable for machining steel, stainless steel, and titanium alloys
COM10	90	10	0.8	91.6	PVD	在MH10F-S的基础上加入铌元素，刀尖红硬性更好，韧性和耐磨性得到提升，通用性较强 Based on MH10F-S, niobium is added to enhance the red hardness, while improving both toughness and wear resistance, offering stronger versatility
MH10F-S	90	10	0.6-0.8	91.8	PVD	适用于不锈钢车削加工，及钢件铸铁的通用铣削加工，在钻削类表现效果优异 Suitable for stainless steel turning, as well as general milling of steel and cast iron, with excellent performance in drilling operations
COM15	89.5	10.5	0.8	91.8	PVD	适用于合金钢、不锈钢的半精、精加工 Suitable for semi-finishing and finishing of alloy steel and stainless steel
COP25T	92.5	7.5	1.2-1.6	90.5	CVD	适用于P类钢件的车削加工 Suitable for turning of P-class steel materials
COK20	94	6	1.2-1.6	92	CVD	适用于球墨铸铁、灰口铸铁，及铜铝等有色金属材料的加工 Suitable for machining ductile cast iron, gray cast iron, and nonferrous metals such as copper and aluminum

所列牌号参数均为典型值，具体请参照我司材质标准技术表。

All listed grade parameters are typical values. Please refer to our material standard technical sheet for detailed specifications.

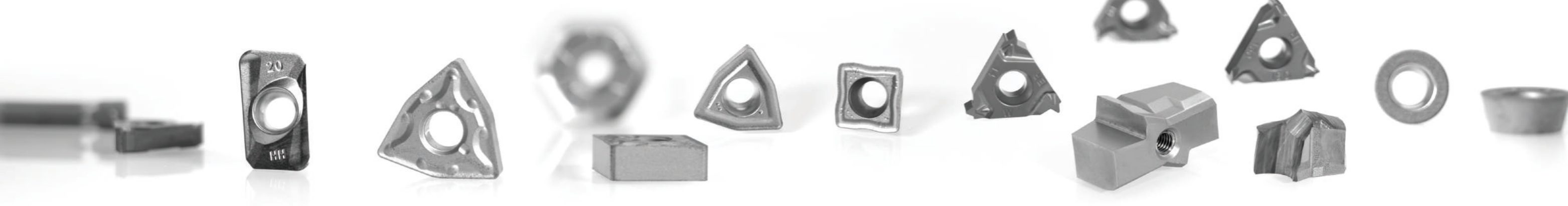

## 应用推荐

## Application Recommendations

加工类型 Machining Type	MH12S	COM10	MH10F-S	COM15	COP25T	COK20
钢件车削 Steel Turning					√	
不锈钢车削 Stainless Steel Turning		√	√			
铸铁车削 Cast Iron Turning						√
通用铣削 General Milling	√	√	√			
铸铁铣削 Cast Iron Milling						√
通用钻削 General Drilling		√	√			
不锈钢螺纹 Stainless Steel Thread				√		
通用皇冠钻 General Crown Drill	√		√			



皇冠钻  
Crown Drills

### 通用皇冠钻基体 Standard Crown Drill Blanks

外形 Shape	型号 Model	使用范围 Scope of Application	基本尺寸 Basic Size (mm)		PVD	
			L	H	MH10F-S	MH12-S
	WLPT1400	D12.50-D13.50	14.1	11.5	●	○
	WLPT1500	D13.51-D14.50	15.1	12.0	●	○
	WLPT1660	D14.51-D15.87	16.6	11.8	●	○
	WLPT1860	D15.88-D18.00	18.6	13.1	●	○
	WLPT2060	D18.01-D19.99	20.6	14.2	●	○
	WLPT2260	D20.00-D22.00	22.6	15.3	●	○
	WLPT2460	D22.01-D24.00	24.6	16.3	●	○
	WLPT2660	D24.01-D26.00	26.6	17.6	●	○
	WLPT2860	D26.01-D28.00	28.6	18.7	●	○
	WLPT3060	D28.01-D30.00	30.6	19.8	●	○
	WLPT3260	D30.01-D32.00	32.6	20.9	●	○
	WLPT3660	D32.01-D36.00	36.6	23.1	●	○
	WLPT4260	D36.01-D40.00	42.6	25.3	●	○
	WLPT4660	D40.01-D45.00	46.0	28.4	●	○
	WLPT5260	D45.01-D52.00	53.0	29.0	●	○

● 常备库存 Ready Stock    ○ 可生产库存 Available for Production

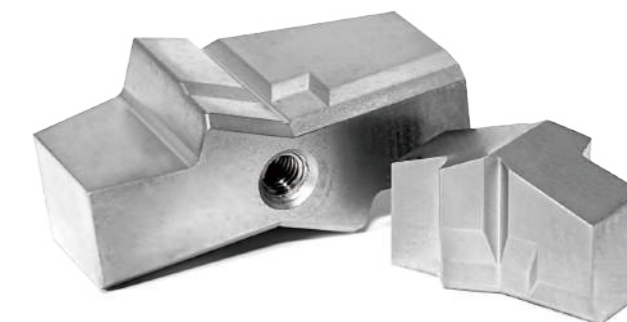
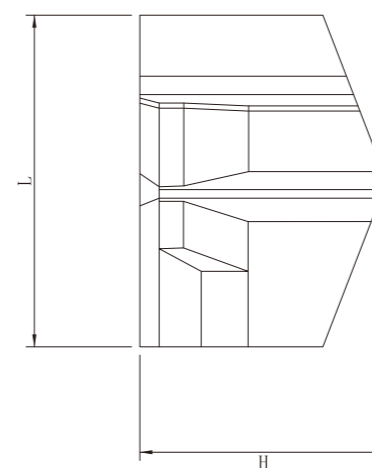

B

切槽刀  
Grooving Inserts

## 通用切槽刀基体









## Standard Parting &amp; Grooving Insert Blanks

外形 Shape	型号 Model	L	基本尺寸 Basic Size (mm)			Re	PVD COM15
			W	S			
	MGMN150-T	16	1.5	3.5	0.15	●	
	MGMN200-T	16	2	3.5	0.2	●	
	MGMN250-T	18.5	2.5	3.85	0.2	●	
	MGMN300-T	21	3	4.8	0.4	●	
	MGMN400-T	21	4	4.8	0.4	●	
	MGMN500-T	26	5	5.9	0.8	●	
	MGMN600-T	26.2	6	5.94	0.8	●	
	MGMN200-M	16	1.6	3.5	2	●	
	MGMN250-M	18.5	2.5	3.85	0.2	●	
	MGMN300-M	21	3	4.8	0.4	●	
	MGMN400-M	21	4	4.81	0.4	●	
	MGMN500-M	26	5	5.9	0.8	●	
	MGMN600-M	25.9	6	5.8	0.8	●	
	MGMN150-G	15.8	1.5	3.5	0.15	●	
	MGMN200-G	16.1	2	3.54	0.2	●	
	MGMN250-G	18.5	2.5	3.85	0.2	●	
	MGMN150-J	16	1.5	3.75	0.15	●	
	MGMN200-J	16.2	2	3.5	0.2	●	
	MGMN250-J	18.6	2.5	3.81	0.2	●	
	MGMN300-J	21.1	3	4.8	0.2	●	
	MGMN400-J	21.1	4	4.82	0.4	●	
	MGMN500-J	26	5	5.5	0.8	●	
	TDXU2	20	2	3.8	0.2	●	
	TDXU3	20	3	3.8	0.3	●	
	TDXU4	20	4	4	0.4	●	
	TDJ2	19.9	2	3.84	0.2	●	
	TDJ3	19.9	3	4	0.2	●	
	TDJ4	20.2	4	4	0.3	●	
	MGMN200-DR	16.1	2	3.5	0.15	●	
	MGMN250-DR	18.6	2.5	3.93	0.2	●	
	MGMN300-DR	21	3	4.8	0.2	●	
	MGMN400-DR	21	4	4.8	0.4	●	
	MGMN500-DR	26	5	6	0.6	●	
	TDC2	19.8	2	3.97	0.2	●	
	TDC3	20	3	4.12	0.2	●	
	TDC4	19.8	4	4.15	0.3	●	

● 常备库存 Ready Stock ○ 可生产库存 Available for Production

## 通用切槽刀基体

## Standard Parting &amp; Grooving Insert Blanks

外形 Shape	型号 Model	L	基本尺寸 Basic Size (mm)			Re	PVD COM15
			W	S			
	MRMN150-M	16.5	1.5	3.5	0.15	●	
	MRMN200-M	15.85	2	3.55	0.2	●	
	MRMN250-M	18.5	2.5	3.85	0.25	●	
	MRMN300-M	20.93	3	4.8	0.3	●	
	MRMN400-M	20.95	4	4.9	0.4	●	
	MRMN500-M	25.85	5	5.8	0.5	●	
	MRMN600-M	25.85	6	5.91	0.6	●	
	MGMN200-C	16.1	2	3.54	0.2	●	
	MGMN300-C	20	3	4.12	0.2	●	
	MGMN400-C	21	4	4.51	0.3	●	
	MGMN150-JMF	15.96	1.5	3.56	0.15	●	
	MGMN200-JMF	15.84	2	3.56	0.2	●	
	MGMN250-JMF	18.42	2.5	3.86	0.2	●	
	MGMN300-JMF	20.9	3	3.89	0.3	●	
	MGMN400-JMF	20.9	4	4.88	0.4	●	
	MGMN500-JMF	20.9	5	5.92	0.7	●	
	TDT300	20	3	4	0.4	●	
	TDT400	20	4	4	0.4	●	
	TDR2	20	2	3.84	0.2	●	
	TDR3	20	3	4	0.3	●	
	TDR4	20	4	4	0.4	●	
	GK18R	18.7	11.2	5.1	6.96	●	
	GK12R	12.4	7.3	3.6	5.9	●	
	GK7R	7.47	5.2	2.55	5.2	●	
	TKF12-L	30.96	7.95	4.1	8.3	●	
	TKF12-R	30.72	7.96	4.1	3.97	●	

● 常备库存 Ready Stock ○ 可生产库存 Available for Production



### 车削刀片命名规格

Naming Rules for Turning Inserts

代号 Code	后角 Relief Angle	代号 Code	孔 Hole	断屑槽 Chip Breaker	截面示意图 Sectional Drawing	代号 Code	孔 Hole	断屑槽 Chip Breaker	截面示意图 Sectional Drawing
A	3°	B	有 Yes	无 No		N	无 No	无 No	
B	5°	H	有 Yes	单面 Single-Sided		R	无 No	单面 Single-Sided	
C	7°	C	有 Yes	无 No		F	无 No	双面 Double-Sided	
D	15°	J	有 Yes	双面 Double-Sided		A	有 Yes	无 No	
E	20°	W	有 Yes	无 No		M	有 Yes	单面 Single-Sided	
F	25°	T	有 Yes	单面 Single-Sided		G	有 Yes	双面 Double-Sided	
G	30°	Q	有 Yes	无 No		X	---	---	特殊 Special
N	0°	U	有 Yes	双面 Double-Sided					
P	11°								
O	其他 Other								

内切圆直径 Incribed Circle Diameter (mm)	刀片形状 Insert Shape							
	C	D	R	S	T	V	W	K
3.97					6			
5.5			5					
5.56					9			
6			6					
6.35	6	7			11	11		
8			8					
9.525	9	11	9	9	16	16	6	16
10			10					
12			12					
12.7	12	15	12	12	22	22	8	
15.875	16		15	15	27			
16		19	16					
19.05	19		19	19	33			
20		25	20					
25	25		25					
25.4			25	25	25			
31.75			31	32	32			
32			32					

代号 Code	厚度 Thickness (mm)
0	0.79
T0	0.99
01	1.59
T1	1.98
02	2.38
T2	2.78
03	3.18
T3	3.97
04	4.76
T4	4.96
05	5.56
T5	5.95
06	6.35
T6	6.75
07	7.94
09	9.52
T9	9.72
10	11.11
12	12.70

代号 Code	厚度 Thickness (mm)	断屑槽型代号 Chip Breaker Code
TM		DL
SL		MA
SM		MV



公差 Tolerance				• 刀尖高度(mm) Cutting Point Height (mm)							
代号 Code	刀尖高度 Cutting Point Height (mm)	内切圆 Incribed Circle ΦIC	厚度 Thickness (mm)	内切圆 Incribed Circle	正三角形 Equilateral Triangle	正方形 Square	80°菱形 80° Rhombic	55°菱形 55° Rhombic	35°菱形 35° Rhombic	圆形 Round	
A	±0.005	±0.025	±0.025	6.35	±0.08	±0.08	±0.08	±0.11	±0.16	---	
F	±0.005	±0.013	±0.025	9.525	±0.08	±0.08	±0.08	±0.11	±0.16	---	
C	±0.013	±0.025	±0.025	12.7	±0.13	±0.13	±0.13	±0.15	---	---	
H	±0.013	±0.013	±0.025	15.875	±0.15	±0.15	±0.15	±0.18	---	---	
E	±0.025	±0.025	±0.025	19.05	±0.15	±0.15	±0.15	±0.18	---	---	
G	±0.025	±0.025	±0.13	25.4	---	±0.18	---	---	---	---	
J	±0.005	±0.05~±0.13	±0.025	• 内切圆 Incribed Circle ΦIC							
K	±0.013	±0.05~±0.13	±0.025	内切圆 Incribed Circle	正三角形 Equilateral Triangle	正方形 Square	80°菱形 80° Rhombic	55°菱形 55° Rhombic	35°菱形 35° Rhombic	圆形 Round	
L	±0.025	±0.05~±0.13	±0.025	6.35	±0.05	±0.05	±0.05	±0.05	±0.05	---	
M	±0.08~±0.18	±0.05~±0.13	±0.13	9.525	±0.05	±0.05	±0.05	±0.05	±0.05	---	
N	±0.08~±0.18	±0.05~±0.13	±0.025	12.7	±0.08	±0.18	±0.08	±0.08	---	---	
U	±0.13~±0.38	±0.08~±0.25	±0.13	15.875	±0.10	±0.10	±0.10	±0.10	---	---	
				19.05	±0.10	±0.10	±0.10	±0.10	---	---	
				25.4	---	±0.13	---	---	---	---	













内切圆 Incribed Circle		厚度 Thickness		刀尖圆弧代号 Tip Arc	
代号 Code	直径 Diameter (Inch)	代号 Code	厚度 Thickness (Inch)	代号 Code	半径 Radius (Inch)
2	1/4	2	1/8	05	0.008
3	3/8	25	5/32	1	1/64
4	1/2	3	3/16	2	1/32
5	5/8	35	7/32	3	3/64
6	3/4	4	1/4	4	1/16
7	7/8	5	5/16	5	5/64
8	1	6	3/8	6	3/32

代号 Code	半径 Radius (Inch)
00	无圆角 No Rounded Corner
02	0.2
04	0.4
08	0.8
12	1.2
16	1.6
20	2.0
24	2.4
32	3.2
X	其他 Other

## 负角车削刀片 (不锈钢加工)

### Negative Turning Inserts (Stainless Steel)

外形 Shape	型号 Model	L	基本尺寸 Basic Size (mm)			Re	PVD	
			IC	S	D		MH10F-S	COM10
	CNMG120404-MA	12	12.7	4.86	5.16	0.4	○	●
	CNMG120408-MA	12	12.7	4.86	5.16	0.8	○	●
	CNMG120412-MA	12	12.7	4.86	5.16	1.2	○	●
	DNMG150404-MA	15	12.7	4.86	5.16	0.4	○	●
	DNMG150408-MA	15	12.7	4.86	5.16	0.8	○	●
	SNMG120404-MA	12	12.7	4.86	5.16	0.4	○	●
	SNMG120408-MA	12	12.7	4.86	5.16	0.8	○	●
	SNMG120412-MA	12	12.7	4.86	5.16	1.2	○	●
	TNMG160404-MA	16	9.53	4.86	3.81	0.4	○	●
	TNMG160408-MA	16	9.53	4.86	3.81	0.8	○	●
	VNMG160404-MA	16	9.525	4.86	3.81	0.4	○	●
	VNMG160408-MA	16	9.525	4.86	3.81	0.8	○	●
	WNMG080404-SM	8	12.7	4.85	5.16	0.4	○	●
	WNMG080408-SM	8	12.7	4.85	5.16	0.8	○	●
	WNMG080412-SM	8	12.7	4.85	5.16	1.2	○	●
	WNMG080404-DF	8	12.7	4.85	5.16	0.4	○	●
	WNMG080408-DF	8	12.7	4.85	5.16	0.8	○	●
	TNMG160404-DF	16	9.525	4.85	3.81	0.4	○	●
	TNMG160408-DF	16	9.525	4.85	3.81	0.8	○	●
	WNMG080408-MS	8	12.7	4.86	5.16	0.8	○	●
	TNMG160408-MS	16	9.525	4.86	3.81	0.8	○	●
	TNMG160404-MS	16	9.525	4.86	3.81	0.4	○	●
	SNMG120404-HA	12	12.7	4.86	5.16	0.4	○	●
	SNMG120404	12	12.7	4.86	5.2	0.4	○	●
	SNMG120404-BC	12	12.7	4.86	5.16	0.4	○	●

● 常备库存 Ready Stock ○ 可生产库存 Available for Production

## 负角车削刀片 (钢件加工)



### Negative Turning Inserts (Steel)

外形 Shape	型号 Model	L	基本尺寸 Basic Size (mm)			Re	CVD COP25T
			IC	S	D		
	CNMG120404-TM	12	12.7	4.86	5.16	0.4	●
	CNMG120408-TM	12	12.7	4.85	5.16	0.8	●
	CNMG120412-TM	12	12.7	4.85	5.16	1.2	●
	CNMG190612-GR	19	19.05	6.45	7.94	1.2	●
	CNMG190616-QR	19	19.05	6.45	7.94	1.6	●
	DNMG150404-TM	15	12.7	4.86	5.16	0.4	●
	DNMG150408-TM	15	12.7	4.86	5.16	0.8	●
	SNMG120404-TM	12	12.7	4.86	5.16	0.4	●
	SNMG120408-TM	12	12.7	4.86	5.16	0.8	●
	TNMG160404-TM	16	9.525	4.85	3.81	0.4	●
	TNMG160408-TM	16	9.525	4.86	3.81	0.8	●
	VNMG160404-TM	16	9.525	4.86	3.81	0.4	●
	VNMG160408-TM	16	9.525	4.86	3.81	0.8	●
	WNMG080404-TM	8	12.7	4.86	5.16	0.4	●
	WNMG080408-TM	8	12.7	4.86	5.16	0.8	●
	WNMG080404L-LF	8	12.7	4.86	5.16	0.4	●
	WNMG080408L-LF	8	12.7	4.86	5.16	0.8	●
	WNMG080404R-LF	8	12.7	4.86	5.16	0.4	●
	WNMG080408R-LF	8	12.7	4.86	5.16	0.8	●
	WNMG080404-DL	8	12.7	4.86	5.16	0.4	●
	WNMG080408-DL	8	12.7	4.86	5.16	0.4	●
	WNMG080412-DL	8	12.7	4.86	5.16	0.4	●

● 常备库存 Ready Stock ○ 可生产库存 Available for Production

## 负角车削刀片 (铸铁加工)







Negative Turning Inserts (Cast Iron)

外形 Shape	型号 Model	L	基本尺寸 Basic Size (mm)			Re	CVD COK20
			IC	S	D		
	SNMA120412	12	12.7	4.96	5.16	1.2	●
	SNMA150612	15	15.875	6.55	6.35	1.2	●
	SNMA190616	19	19.05	6.55	7.94	1.6	●
	CNMA190612	19	19.05	6.55	7.94	1.2	●
	CNMA120404	12	12.7	4.96	5.16	0.4	●
	CNMA120408	12	12.7	4.96	5.16	0.8	●
	CNMA120412	12	12.7	4.96	5.16	1.2	●
	TNMA160404	16	9.525	4.96	3.81	0.4	●
	TNMA160408	16	9.525	4.96	3.81	0.8	●
	WNMA080404	8	12.7	4.96	5.16	0.4	●
	WNMA080408	8	12.7	4.96	5.16	0.8	●
	CNMG120408-CK	12	12.7	4.86	5.16	0.8	●
	CNMG120412-CK	12	12.7	4.86	5.16	1.2	●
	CNMG120404-CK	12	12.7	4.86	5.16	0.4	●
	CNMG160612-CK	16	15.875	6.45	6.35	1.2	●
	CNMG160608-CK	16	15.875	6.45	6.35	0.8	●
	SNMG120408-CK	12	12.7	4.86	5.16	0.8	●
	SNMG120412-CK	16	12.7	4.86	5.16	1.2	●
	TNMG160404-CK	16	9.525	4.86	3.81	0.4	●
	TNMG160408-CK	16	9.525	4.86	3.81	0.8	●
	TNMG160412-CK	16	9.525	4.86	3.81	1.2	●
	WNMG080404-CK	8	12.7	4.86	5.16	0.4	●
	WNMG080408-CK	8	12.7	4.86	5.16	0.8	●
	WNMG080412-CK	8	12.7	4.86	5.16	1.2	●
	WNMG160404-CK	16	9.525	4.86	3.81	0.4	●
	WNMG160408-CK	16	9.525	4.86	3.81	0.8	●
	DNMG150404-CK	15	12.7	4.86	5.16	0.4	●
	DNMG150408-CK	15	12.7	4.86	5.16	0.8	●
	DNMG150412-CK	15	12.7	4.86	5.16	1.2	●

● 常备库存 Ready Stock ○ 可生产库存 Available for Production

## 正角车削刀片 (不锈钢加工)

Positive Turning Inserts (Stainless Steel)

外形 Shape	型号 Model	L	基本尺寸 Basic Size (mm)			Re	PVD	
			IC	S	D		MH10F-S	COM10
	CCMT060202-SL	6	6.35	2.48	2.8	0.2	○	●
	CCMT060204-SL	6	6.35	2.48	2.8	0.4	○	●
	CCMT060208-SL	6	6.35	2.48	2.8	0.8	○	●
	CCMT09T304-SL	9	9.525	4.07	4.5	0.4	○	●
	CCMT09T308-SL	9	9.525	4.07	4.5	0.8	○	●
	TCMT110204-SL	11	6.35	2.48	2.8	0.4	○	●
	TCMT110208-SL	11	6.35	2.48	2.8	0.8	○	●
	TCMT16T304-SL	16	9.525	4.07	4.4	0.4	○	●
	TCMT16T308-SL	16	9.525	4.07	4.4	0.8	○	●
	VBMT110302-MV	11	6.35	3.28	2.8	0.2	○	●
	VBMT110304-MV	11	6.35	3.28	2.8	0.4	○	●
	VBMT160404-MV	16	9.525	4.86	4.5	0.4	○	●
	VBMT160408-MV	16	9.525	4.86	4.5	0.8	○	●
	DCMT070202-MV	7	6.35	2.48	2.8	0.2	○	●
	DCMT070204-MV	7	6.35	2.48	2.8	0.4	○	●
	DCMT070208-MV	7	6.35	2.48	2.8	0.8	○	●
	DCMT11T302-MV	11	9.525	4.07	4.4	0.2	○	●
	DCMT11T304-MV	11	9.525	4.07	4.4	0.4	○	●
	DCMT11T308-MV	11	9.525	4.07	4.4	0.8	○	●
	CCMT120404	12	12.7	4.86	5.5	0.4	○	●
	CCMT120408	12	12.7	4.86	5.5	0.8	○	●
	DCMT11T304	11	9.525	4.07	4.4	0.4	○	●
	DCMT11T308	11	9.525	4.07	4.4	0.8	○	●

● 常备库存 Ready Stock ○ 可生产库存 Available for Production

## 小零件加工刀片 Turning Inserts for Small Parts

外形 Shape	型号 Model	L	基本尺寸 Basic Size (mm)			Re	PVD COM15
			IC	S	D		
	DCRT11T302F-PF	11	9.95	4.14	4.4	0.32	●
	VBRT110302F-PF	11	6.79	3.31	2.8	0.45	●
	CCRT060202-PF	6	10.03	4.1	4.4	0.45	●
	CCRT09T302-PF	9	6.85	2.52	2.8	0.45	●
	DCRT070202-PF	7	6.85	2.52	2.8	0.45	●
	DCRW110302	11	9.95	4.17	4.4	0.32	●
	VBRW110302	11	6.78	3.38	2.8	0.28	●

● 常备库存 Ready Stock    ○ 可生产库存 Available for Production

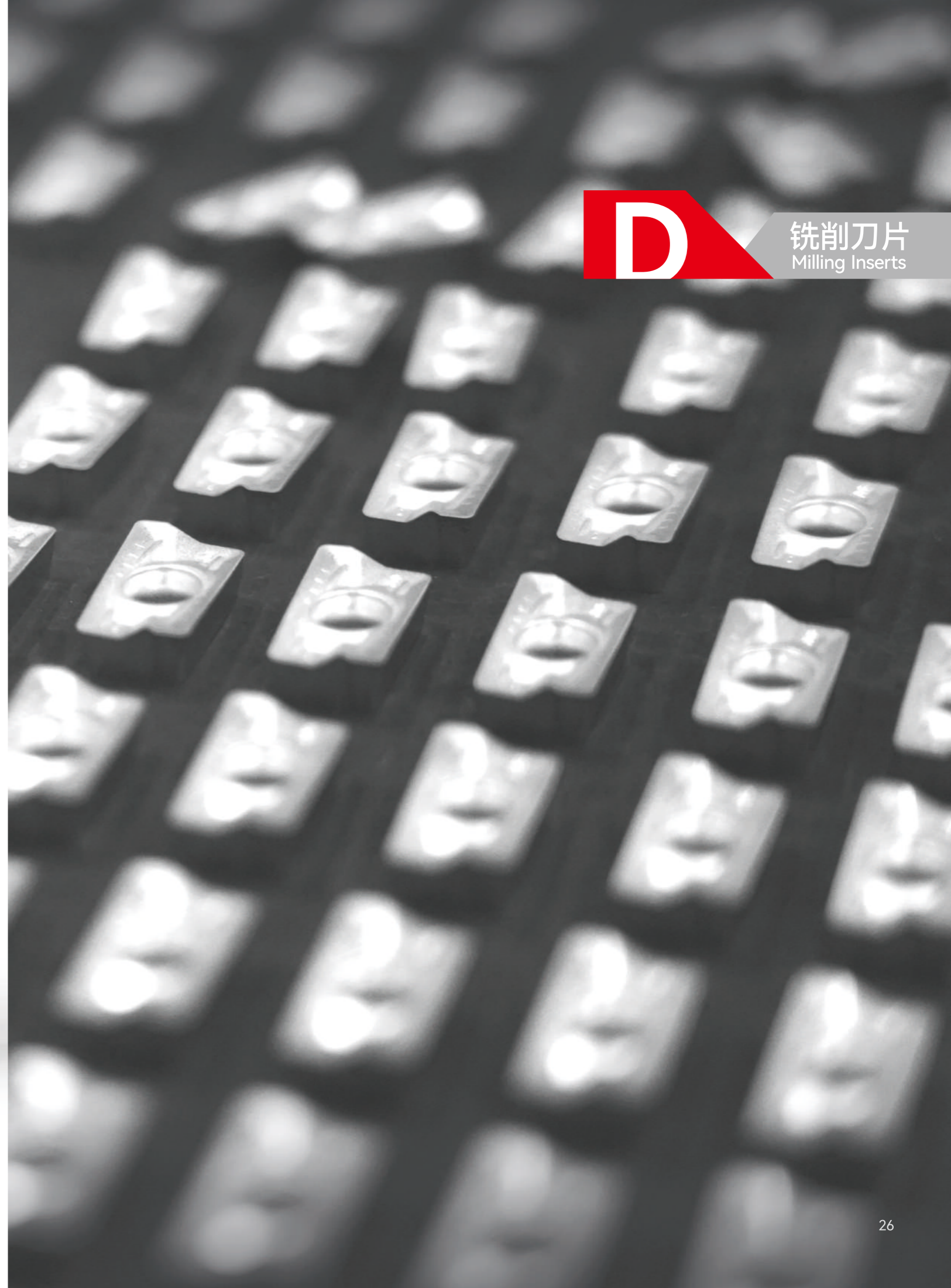

### 铣削刀片命名规格

#### Naming Rules for Milling Inserts

代号 Code	后角 Relief Angle	代号 Code	孔 Hole	断屑槽 Chip Breaker	截面示意图 Sectional Drawing	代号 Code	孔 Hole	断屑槽 Chip Breaker	截面示意图 Sectional Drawing
A	3°	B	有 Yes	无 No		N	无 No	无 No	
B	5°	H	有 Yes	单面 Single-Sided		R	无 No	单面 Single-Sided	
C	7°	C	有 Yes	无 No		F	无 No	双面 Double-Sided	
D	15°	J	有 Yes	双面 Double-Sided		A	有 Yes	无 No	
E	20°	W	有 Yes	无 No		M	有 Yes	单面 Single-Sided	
F	25°	T	有 Yes	单面 Single-Sided		G	有 Yes	双面 Double-Sided	
G	30°	Q	有 Yes	无 No		X	---	---	特殊 Special
N	0°	U	有 Yes	双面 Double-Sided					
P	11°								
O	其他 Other								

内切圆直径 Inscribed Circle Diameter (mm)	刀片形状 Insert Shape							
	C	D	R	S	T	V	W	K
3.97					6			
5.5			5					
5.56					9			
6			6					
6.35	6	7			11	11		
8			8					
9.525	9	11	9	9	16	16	6	16
10			10					
12			12					
12.7	12	15	12	12	22	22	8	
15.875	16		15	15	27			
16		19	16					
19.05	19		19	19	33			
20		25	20					
25	25		25					
25.4			25	25	25			
31.75			31	32	32			
32			32					

代号 Code	厚度 Thickness (mm)
0	0.79
T0	0.99
01	1.59
T1	1.98
02	2.38
T2	2.78
03	3.18
T3	3.97
04	4.76
T4	4.96
05	5.56
T5	5.95
06	6.35
T6	6.75
07	7.94
09	9.52
T9	9.72
10	11.11
12	12.70

代号 Code	角度 Angle	代号 Code	角度 Angle
A	45°	A	3°
D	60°	B	5°
E	75°	C	7°
F	85°	D	15°
P	90°	E	20°
Z	Others	F	25°
		G	30°
		N	0°
		P	11°
		Z	Others

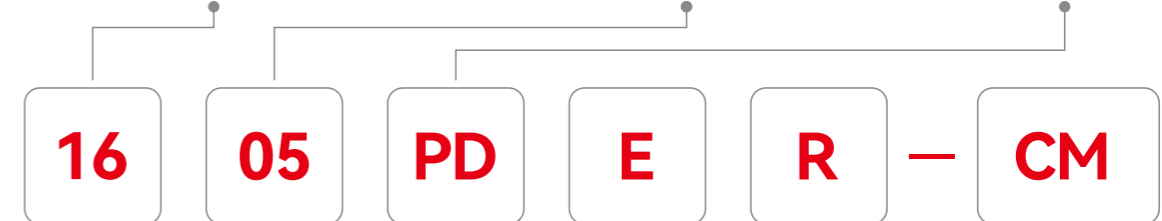

公差 Tolerance				• 刀尖高度(mm) Cutting Point Height (mm)							
代号 Code	刀尖高度 Cutting Point Height (mm)	内切圆 Inscribed Circle ΦIC	厚度 Thickness (mm)	内切圆 Inscribed Circle	正三角形 Equilateral Triangle	正方形 Square	80°菱形 80° Rhombic	55°菱形 55° Rhombic	35°菱形 35° Rhombic	圆形 Round	
A	±0.005	±0.025	±0.025	6.35	±0.08	±0.08	±0.08	±0.11	±0.16	---	
F	±0.005	±0.013	±0.025	9.525	±0.08	±0.08	±0.08	±0.11	±0.16	---	
C	±0.013	±0.025	±0.025	12.7	±0.13	±0.13	±0.13	±0.15	---	---	
H	±0.013	±0.013	±0.025	15.875	±0.15	±0.15	±0.15	±0.18	---	---	
E	±0.025	±0.025	±0.025	19.05	±0.15	±0.15	±0.15	±0.18	---	---	
G	±0.025	±0.025	±0.13	25.4	---	±0.18	---	---	---	---	
J	±0.005	±0.05~±0.13	±0.025								
K	±0.013	±0.05~±0.13	±0.025								
L	±0.025	±0.05~±0.13	±0.025								
M	±0.08~±0.18	±0.05~±0.13	±0.13								
N	±0.08~±0.18	±0.05~±0.13	±0.025								
U	±0.13~±0.38	±0.08~±0.25	±0.13								







切削刃倒棱 Cutting Edge Chamfer								
F	E		T			S		
	0	1	2	3	4	5		
	5°	10°	15°	20°	25°	30°		
	0	1	2	3	4	5	6	7
	0.1	0.15	0.2	0.25	0.3	0.35	0.4	0.45

切削方向 Cutting Direction	
代号 Code	方向 Direction
R	右 Right
L	左 Left
N	双向 Both

断屑槽型代号 Chip Breaker Code	
代号 Code	断屑槽型代号
CR	CR
CM	CM

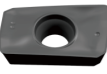
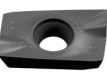
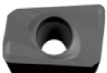
## 通用铣削刀片

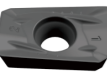
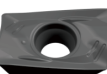
### Standard Milling Inserts

外形 Shape	型号 Model	L	基本尺寸 Basic Size (mm)			Re	MH10F-S	PVD	
			W	S	D			COM10	MH12S
	EPMW0603-8	10	6.35	3.28	2.9	0.8	○	●	○
	JDMT070208R	7.07	4.26	2.56	2	0.8	●	○	○
	JDMT070204R	7.07	4.26	2.56	2	0.4	●	○	○
	APMT1135PDER-DL	11.35	6.2	3.6	2.8	0.8	●	●	○
	APMT1604PDER-DL	17.32	9.36	5.35	4.4	0.8	●	●	○
	APMT1135PDER-H2	11.29	6.15	3.6	2.8	0.8	●	●	○
	APMT1135R20-H2	11.34	6.21	3.64	2.8	2	●	●	○
	APMT1135-R12	11.37	6.21	3.64	2.8	1.2	●	●	○
	APMT1135-R16	11.35	6.21	3.64	2.8	1.6	●	●	○
	APMT1604PDER-H2	17.25	9.25	4.86	4.4	0.8	●	●	○
	APMT1604-R12	17.08	9.3	4.86	4.5	1.2	●	●	○
	APMT1604-R16	17.08	9.3	4.86	4.5	1.6	●	●	○
	APMT1135PDER-M2	11	6.16	3.6	2.8	0.8	●	●	○
	APMT1604PDER-M2	16	9.25	4.86	4.4	0.8	●	●	○
	APMT160420PDER-HH	16	9.25	4.86	4.4	2	●	●	○
	APMT160430PDER-HH	16	9.3	4.76	4.5	3	●	●	○
	APMT1135PDER-CM	11.25	6.26	3.6	2.8	0.8	●	●	○
	APMT1604PDER-CM	17.44	9.32	5.3	4.6	1.52	●	●	○
	R390-11T308M-PM	11.75	6.83	3.71	2.8	0.8	●	○	○
	BLMP0603R-M	9.05	6.45	3.365	3.2	0.4	●	○	○
	BLMP0904R-M	11.94	9.15	4.07	4.15	0.4	●	○	○

● 常备库存 Ready Stock ○ 可生产库存 Available for Production

## 通用铣削刀片







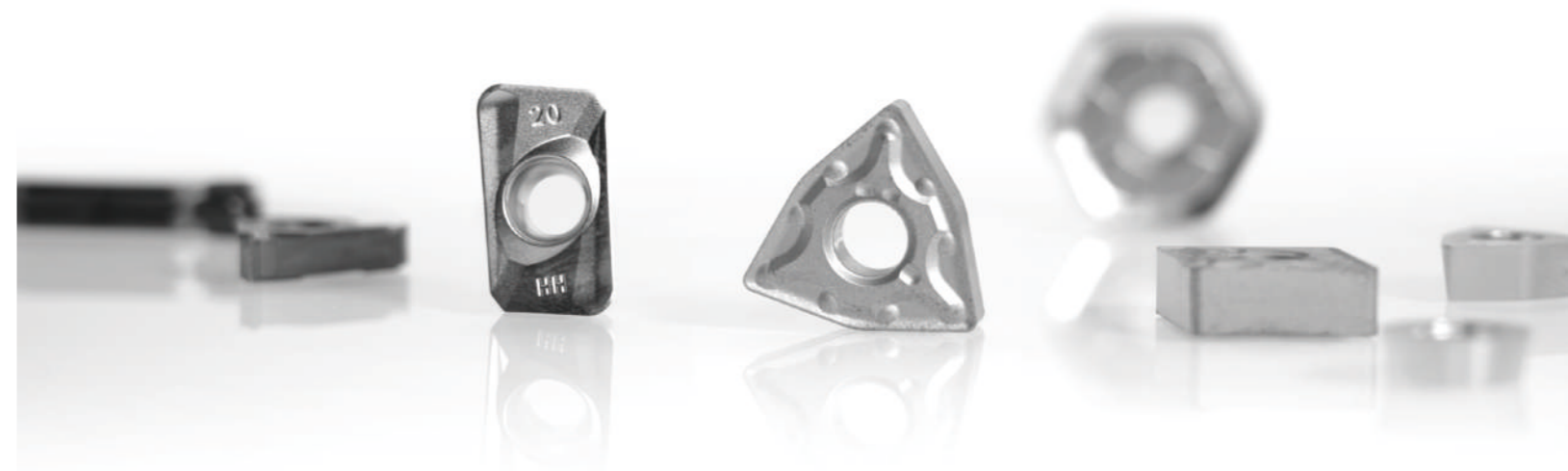





### Standard Milling Inserts

外形 Shape	型号 Model	L	基本尺寸 Basic Size (mm)			Re	MH10F-S	PVD	
			W	S	D			COM10	MH12S
	LNMU0303ZER-DZ	11.88	6	3.7	2.8	1.2	●	○	○
	LNMU0303ZER-MJ	11.88	6	3.7	2.8	0.3	●	○	○
	LNPU116508-S	12.1	6.6	4.83	3.5	0.8	●	○	○
	LORU030310ER-GMX	12.36	6.5	4.05	3.7	1	●	○	○

● 常备库存 Ready Stock ○ 可生产库存 Available for Production















### 通用铣削刀片 Standard Milling Inserts

外形 Shape	型号 Model	L	基本尺寸 Basic Size (mm)			Re	MH10F-S	PVD	
			IC	S	D			COM10	MH12S
	4NMT060308R-M	6	6.6	3.65	3.34	0.8	○	○	○
	4NKT040208R-M	4	4.5	2.6	2.2	0.8	○	○	○
	ONMU060408-GM	6	15.88	5	4.35	0.8	●	○	○
	XNMU070508-MM4	7	14.5	5.4	4.07	0.8	●	○	○
	HNMX0906ANSN-M	8	16.5	6.33	4.8	0.8	●	○	○
	ODMT050408-MR	5	12.7	4.88	4.4	0.8	●	○	○
	ODMT0605ANN-MR	6	15.875	5.66	5.5	0.8	●	○	○
	RPMT1204MO-DL	12	12	4.86	4.4	/	●	●	○
	RPMW1003MO-DL	10	10	3.28	4.6	/	●	●	○
	SEMR1203AFTN	12	12.6	3.29	2.6	0.8	●	○	○
	SEMR1504AFTN	15	15.8	4.82	3.2	0.8	●	○	○
	PDMX090530	9	13.5	5.56	5.5	3	●	○	○
	RPMT1204M0-CM	12	12	4.86	4.4	/	●	●	○
	RPMT1003M0-CM	10	10	3.28	4.6	/	●	●	○
	RPMW1003M0	10	10	3.34	4.6	/	●	●	○
	RPMW08T2MO	8	8.06	2.98	3.06	/	○	●	○











● 常备库存 Ready Stock ○ 可生产库存 Available for Production

### 通用铣削刀片 Standard Milling Inserts

外形 Shape	型号 Model	L	基本尺寸 Basic Size (mm)			Re	MH10F-S	PVD	
			IC	S	D			COM10	MH12S
	SEKT1204AFSN-R	12	12.66	4.86	5.6	/	○	○	●
	PNMU0905XER	9	13.46	5.48	4.65	/	●	○	○
	RPMT10T3MO-T	10	10	4.07	4.4	/	○	●	○
	RDMT10T3MOTN	10	10	4.07	4.4	/	○	●	○
	RDMW1204MO-R6	12	12	4.86	4.4	/	●	●	○
	RDMW1605MO-R8	16	16	5.66	5.5	/	○	●	○
	SDMT1205ZDTN-R15	12	12.7	5.64	4.6	2.5	○	●	○
	SDMT150512-GM	15	15.84	5.66	5.5	1.2	○	●	○
	SDMT120512-GH	12	12.65	5.66	4.4	1.2	○	●	○
	SDMT150512-GH	15	15.82	5.56	5.5	1.2	○	●	○
	SDMT140520ER-LD	14	14.86	5.66	5.85	2	○	●	○
	SOMT100420ER-GM	10	10.3	4.6	4.7	2	○	○	●
	SOMT140520ER-GM	14	14.14	5.66	5.85	2	○	○	●
	WNMU040304EN-GM	4	6.7	3.06	3.2	0.4	○	○	●
	WNMU060408R-M	6	10.15	4.36	4.2	0.8	○	○	●

● 常备库存 Ready Stock ○ 可生产库存 Available for Production





## 通用铣削刀片 Standard Milling Inserts

外形 Shape	型号 Model	L	基本尺寸 Basic Size (mm)			Re	MH10F-S	PVD		MH12S
			IC	S	D			COM10		
	WNMU080608EN-GMA	8	14.02	6.63	6.2	0.8	●	○	○	
	WNMU080608R-ME09	8	12.5	6.38	4.6	0.8	●	○	○	
	WNMU080608EN-GHA	8	14.02	6.66	6.2	0.8	●	○	○	
	SNMU1206XTN	12	12.7	6.35	5.54	0.4	○	○	●	
	SNMU120612-M	12	12.7	5.56	6	1.2	○	○	●	
	SNMU120608-M	12	12.7	5.56	6	0.8	○	○	●	
	SNMU1206ANN-M	12	12.7	6.2	5.95	0.8	○	○	●	
	SNMU1306EN-SM	12	13	5.47	4.85	0.8	○	○	●	
	SNMX1206QNN-M	12	12.7	6.35	5.9	0.8	○	○	●	
	MPMT060304-DM	6	6.35	3.28	2.8	0.4	○	●	○	
	MPMT080305-DM	8	8.3	3.3	3.4	0.5	○	●	○	
	MPMT120408-DM	12	12.7	4.86	5.6	0.8	○	●	○	
	SNHX1202	12	12.7	2.5	5.15	0.08	○	○	○	
	SNHX1203	12	12.7	3.2	5.15	0.08	○	○	○	
	SNHX12T3	12	12.7	3.7	5.15	0.08	○	○	○	
	SNHX1204	12	12.7	4.2	5.15	0.08	○	○	○	
	SNHX12T4	12	12.7	4.7	5.15	0.08	○	○	○	
	SNHX12T5	12	12.7	5.2	5.15	0.08	○	○	○	

● 常备库存 Ready Stock ○ 可生产库存 Available for Production













## 通用钻削刀片 Standard Drilling Inserts

外形 Shape	型号 Model	L	基本尺寸 Basic Size (mm)			Re	PVD MH10F-S
			IC	S	D		
	WCMX030208-U	3	5.56	2.48	2.8	0.8	●
	WCMX040208-U	4	6.35	2.48	3	0.8	●
	WCMX050308-U	5	7.94	3.28	3.4	0.8	●
	WCMX06T308-U	6	9.525	4.07	3.8	0.8	●
	WCMX080412-U	8	12.7	4.86	4.4	1.2	●
	SPMG050204-DG	5	5	2.48	2.4	0.4	●
	SPMG060204-DG	6	6	2.48	2.6	0.4	●
	SPMG07T308-DG	7	7.94	4.1	2.8	0.8	●
	SPMG090408-DG	9	9.8	4.45	4.2	0.8	●
	SPMG110408-DG	11	11.5	4.9	4.4	0.8	●
SPMG140512-DG	14	14.35	5.35	5.76	1.2	●	
	WCMX030208	3	5.56	2.45	2.8	0.8	●
	WCMX040208	4	6.35	2.45	3.1	0.8	●
	WCMX050308	5	7.94	3.28	3.3	0.8	●
	WCMX06T308	6	9.525	4.07	3.8	0.8	●
	WCMX080412	8	12.7	4.86	4.4	1.2	●
	SOMT040204-DP	4	4.12	2.38	2	0.4	●
	SOMT050204-DP	5	4.9	2.38	2.25	0.4	●
	SOMT060204-DP	6	5.7	2.38	2.6	0.4	●
	SOMT070306-DP	7	6.8	2.8	2.6	0.6	●
	SOMT08T306-DP	8	7.9	4.07	2.85	0.6	●
	SOMT09T308-DP	9	9.2	4.07	3.85	0.8	●
	SOMT11T308-DP	11	11	4.07	3.81	0.8	●
SOMT130408-DP	13	12.8	4.5	4.4	0.8	●	
SOMT150510-DP	15	15	4.9	5.4	1	●	

● 常备库存 Ready Stock ○ 可生产库存 Available for Production



## 不锈钢螺纹刀片 Standard Drilling Inserts

外形 Shape	型号 Model	L	基本尺寸 Basic Size (mm)			Re	PVD COM15
			IC	S	D		
	16R150ISO-HR	/	9.525	3.62	4	0.11	●
	16ER150ISO-HR	/	9.525	3.62	4	0.22	●
	16R200ISO-HR	/	9.525	3.63	4	0.15	●
	16ER200ISO-HR	/	9.525	3.64	4	0.29	●
	16ERAG60-HR	/	9.525	3.62	4	0.1	●
	16IRAG60-HR	/	9.525	3.61	4	0.1	●
	16ER14W-HR	/	9.525	3.62	4	0.24	●
	16IR14W-HR	/	9.525	3.62	4	0.24	●
	16ER11W-HR	/	9.525	3.62	4	0.3	●
	16IR11W-HR	/	9.525	3.63	4	0.3	●

● 常备库存 Ready Stock ○ 可生产库存 Available for Production



通用技术信息  
General Technical Information

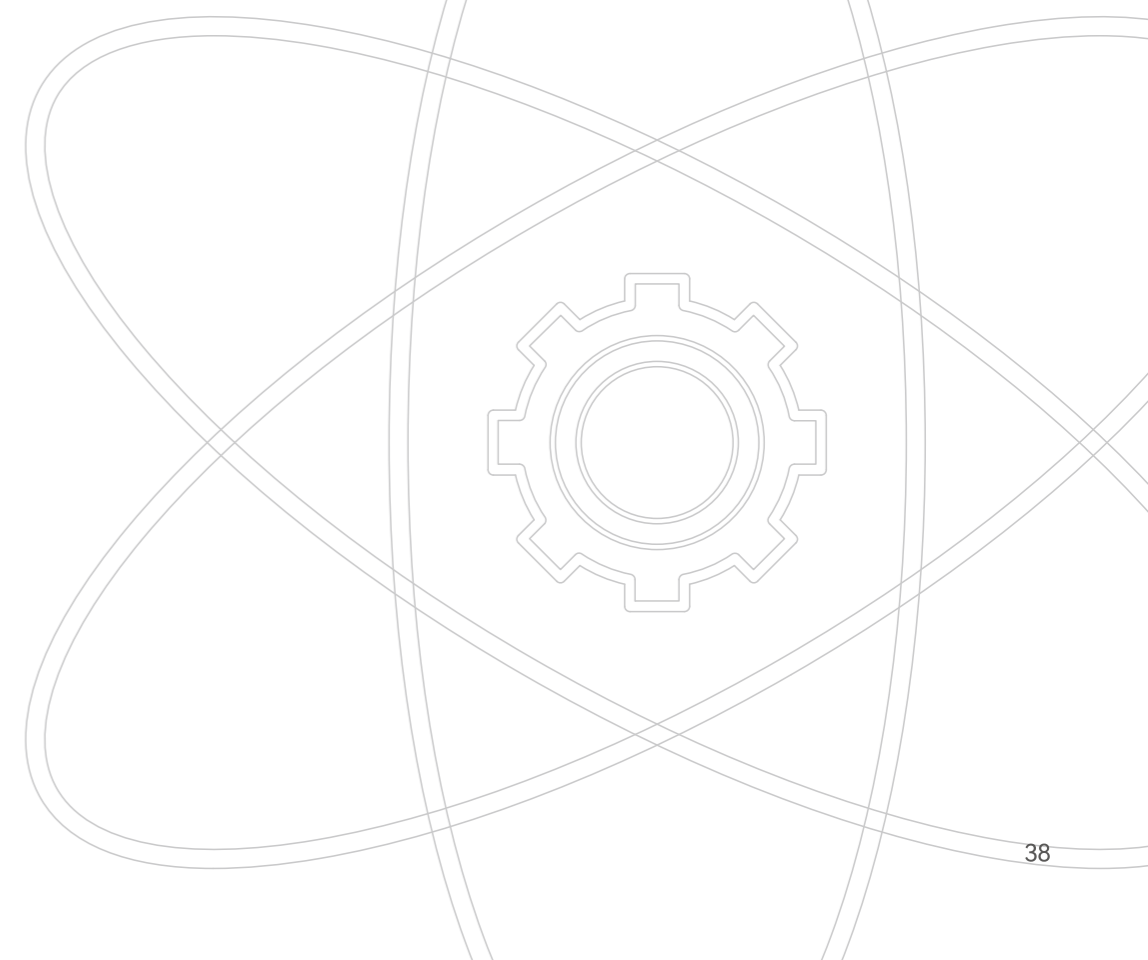
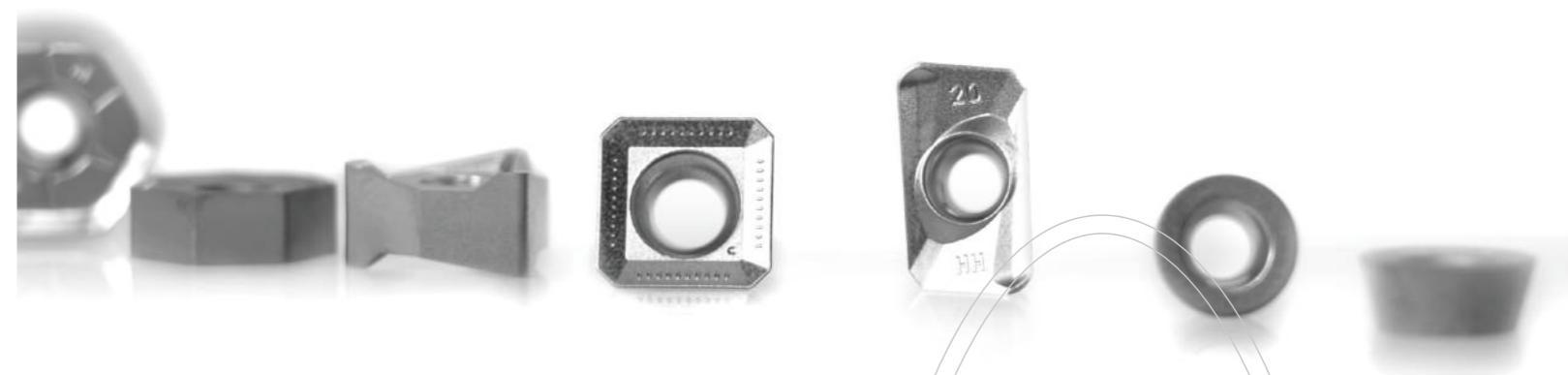

## 刀具规格选用方法

### Tool Specification Selection Guide

#### 车削刀具规格选用办法: Turning Tool Selection Method

- 一、了解您所需加工的材料状况、机床型号及状态。
- 二、选择刀片形状，切削主偏角及装夹方式。
- 三、确定刀杆的左右方向及尺寸等明细。
- 四、选定刀片规格。

- 1.Understand the material, machine type, and machining condition.
- 2.Select the insert shape, cutting edge angle, and clamping method.
- 3.Determine the toolholder's orientation (left-hand or right-hand) and detailed dimensions.
- 4.Choose the appropriate insert grade.

#### 铣削刀具规格选用办法: Milling Tool Selection Method

- 一、了解加工的材料状况、机床型号及状态。
- 二、确定基本类型(面铣、方肩铣、仿形铣、槽铣)。
- 三、确定采用整体铣刀或可转位铣刀。
- 四、确定刀具的接口、尺寸等。
- 五、选定刀片规格。

- 1.Understand the material, machine type, and machining condition.
- 2.Identify the type of milling cutter (Face Milling / Shoulder Milling / Profile Milling / Slot Milling).
- 3.Determine whether to use a solid end mill or an indexable milling cutter.
- 4.Select the insert shape, size, and nose radius.
- 5.Choose the suitable insert grade.

#### 孔加工刀具规格选用办法: Drilling Tool Selection Method

- 一、了解加工的材料状况、机床型号及状态。
- 二、确定刀具的基本类型(钻削、镗削、铰削、螺纹加工等)。
- 三、确定采用整体刀具或可转位孔加工刀具。
- 四、确定刀具的接口、尺寸等。
- 五、选定刀片规格、牌号。

- 1.Understand the material condition, machine model, and operating status.
- 2.Identify the basic type of tool required (drilling, boring, reaming, or threading).
- 3.Determine whether to use a solid tool or an indexable drilling tool.
- 4.Specify the tool interface, dimensions, and related details.
- 5.Select the appropriate insert specification and grade.

## 硬质合金产品安全标准

### Safety Standards for Cemented Carbide Products

#### 安全责任: Safety Responsibility

使用昆山长鹰硬质材料科技股份有限公司生产的产品前，应对使用操作者进行必要的安全培训，并仔细阅读产品包装上的安全注意事项。对没有按有关要求使用操作所造成的不良后果，本公司不承担任何法律责任。

Before using products manufactured by us, users must ensure that all operators have received proper safety training and have carefully read the safety instructions on the product packaging. The company shall not be held legally responsible for any adverse consequences resulting from improper use or failure to follow the relevant operating requirements.

#### 硬质合金刀具使用注意事项: Precautions for Using Carbide Tools

- 1、硬质合金刀刃锋利，材料硬度高，比较脆，作用力大可致脆裂破损，造成伤害。
- 2、在切削加工过程中不可避免的产生切屑、脆片等，操作人员必须穿戴好防护服、防护眼镜等劳保用品。
- 3、硬质合金密度大，搬运和存储要按重物对待，小心轻放。
- 4、硬质合金刀具应存储在干燥、无腐蚀性气氛的环境中。
- 5、硬质合金与钢铁的热膨胀系数不一样，焊接时应适当的温度下进行，避免应力集中造成焊接裂纹。
- 6、为提高加工机床和切削刀具的使用寿命，请正确选择冷却方式。
- 7、加工生产过程中，发现已产生裂纹的刀具，请勿再继续使用。
- 8、磨损换下来的硬质合金刀具和碎片，请回收保管好，避免他人使用造成伤害。

- 1.Carbide cutting edges are sharp and extremely hard but brittle. Excessive impact or force may cause chipping or fracture, leading to potential injury.
- 2.During machining, chips and fragments are inevitably produced. Operators must wear proper protective clothing, safety glasses, and other personal protective equipment (PPE).
- 3.Carbide has a high density; handle and store it carefully as a heavy item to prevent damage.
- 4.Store carbide tools in a dry environment free from moisture and corrosive gases.
- 5.The coefficient of thermal expansion of carbide differs from that of steel. When brazing, perform the operation at an appropriate temperature to avoid stress concentration and cracking.
- 6.To extend the service life of both machine tools and cutting tools, select the proper cooling method during machining.
- 7.Do not continue to use any tool that has developed cracks during machining operations.
- 8.Collect and properly store worn or broken carbide tools and fragments to prevent secondary injuries caused by improper handling or reuse.