

Headquarters: **CY CARBIDE MFG.CO.,LTD.**  
Add: 215316, No. 67, Yucheng Road (N.), Kunshan, Jiangsu, China  
Tel: +86 400 863 2919  
Email: [info@cycarbide.com](mailto:info@cycarbide.com)

Manufacturing Plant: **CK NEW MATERIAL MFG. CO.,LTD.**

## Precision Inserts Catalogue



Where your **innovation**  
BEGINS



● Global Sales Network

## Contents

About Us	01
R&D Center	03
Laboratory Analysis Center	04
Manufacturing Process	05
Main Turning Inserts Chipbreaker	09
Application Arrange of Chipbreaker	11
Grade Chart	12
<b>A</b> Turning Inserts	
Turning Insert Code System (ISO)	17
Negative Turning Inserts	19
Positive turning inserts	30
<b>B</b> Milling Inserts	
Milling Insert Code System (ISO)	37
Milling Inserts	39
<b>C</b> Drilling Inserts	
Standard Drilling Inserts	42
<b>D</b> Grooving Inserts	
Parting & Grooving Inserts	44
<b>E</b> Threading Inserts	
Threading Insert Code System (ISO)	46
ISO Metric Thread, 60° Thread Profile	47
General-Purpose Thread	49
UN (Unified National) Thread	50
Whitworth Thread	51
American Standard Pipe Thread	52
British Standard Pipe Thread	53
<b>F</b> Cermet Turning Inserts	
Negative Cermet Turning Inserts	55
Positive Cermet Turning Inserts	56
<b>G</b> General Technical Information	
Selection Method of Cutting Tools	58
Carbide Products Safety Standard	59
Safety Problems and Protective Measures	60
Inserts Metric and Inch Comparison Table	62
Chipbreaker Comparison Table	64
Grade Comparison Table	65
Material Comparison Table	68
Hardness Comparison Table	74

 **20<sup>+</sup>** Since Foundation

 **800<sup>+</sup>** Employees

 **4** Plants

 **2500** Annual Capacity

 **100<sup>+</sup>** Grades  
**100,000<sup>+</sup>** Specs

 **50<sup>+</sup>** Countries/Regions

## About Us

**Founded in 2003, CY CARBIDE specializes in the development and manufacturing of precision CNC inserts under the brand “CYCT”.**

CYC operates world-class R&D and production lines—from powder preparation to finished coatings—featuring +GF+ EDM/WEDM, Osterwalder and Dorst presses, Shimadzu Sinter-HIP, Balzers PVD, and Ionbond CVD systems. With deep expertise in substrate materials and surface coatings, CYC offers a full range of turning, milling, drilling, parting & grooving, and threading inserts, delivering solid performance in cutting accuracy, efficiency, and tool life.

Innovation is the core driving force behind CYC's development. Over the years, CYC has collaborated with research teams from multiple top-tier universities, continuously advancing studies on carbide base materials and cutting-edge tooling technologies, achieving notable results. The company holds over 40 granted patents. Its products not only serve general machining industries but also find in-depth applications in specialized fields such as precision molds, green energy, 3C, aerospace, rail transit, marine engineering, and heavy equipment, striving to deliver higher performance and more reliable cutting solutions to customers.

**CYC adheres to responsible and sustainable business practices. It is an ISO 9001:2015 (TUV), ISO 14001:2015, ISO 50001:2018, and ISO 45001:2018 certified company with a Silver Medal rating from ecovadis .**

High-performance products are supported by a robust process management system, ensuring consistent quality across all product groups. Strict control of raw material supply chains and 100% traceability for every production batch are maintained throughout the entire manufacturing process. Continuous improvement in every process is a core operating principle.

Its open and transparent business philosophy inspires confidence among customers, employees, and external suppliers in the company, its operations, and its products.



### R&D Center



#### Team

With over 20 years of R&D and manufacturing experience, CYC has built a dedicated team consisting of global experts in technical and commercial areas who always stand behind our customers.



#### Facility

The full range of advanced R&D facilities, seperated prototyping line and cutting test center, provide a solid foundation for new product development.



#### Collaboration

Maintains close and in-depth collaboration with the leading universities, institutions and industry experts.

### Laboratory Analysis Center

▶ JEOL SEM Japan



The internal laboratory's testing scope covers from incoming raw materials (WC, Co, etc.), RTP to carbide blanks and finished parts. Testing items including but not limited to:

- Chemical compositions
- Grain size distribution
- Metallographic micro structure
- Magnetic saturation & coercive force
- Physical & mechanical properties

With the well-equipped facilities and professional methodologies, the lab provides reliable data support and effective quality control for R&D and massive production.



▶ Hexagon CMM

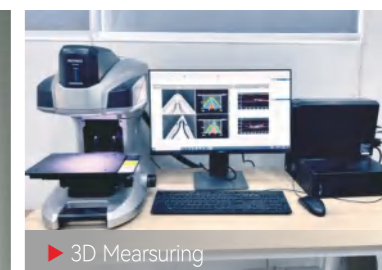

▶ 3D Mearsuring

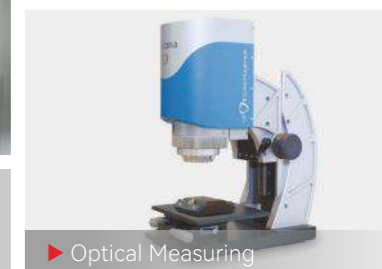

▶ Optical Measuring

## Manufacturing Process

**01** Grade Design  
Material's Selection



**02** RTP  
Ball Milling



**03** RTP  
Spray Drying

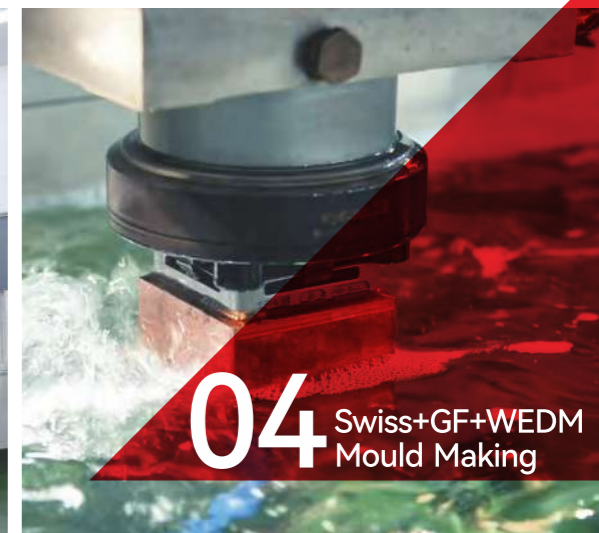

**04** Swiss+GF+WEDM  
Mould Making

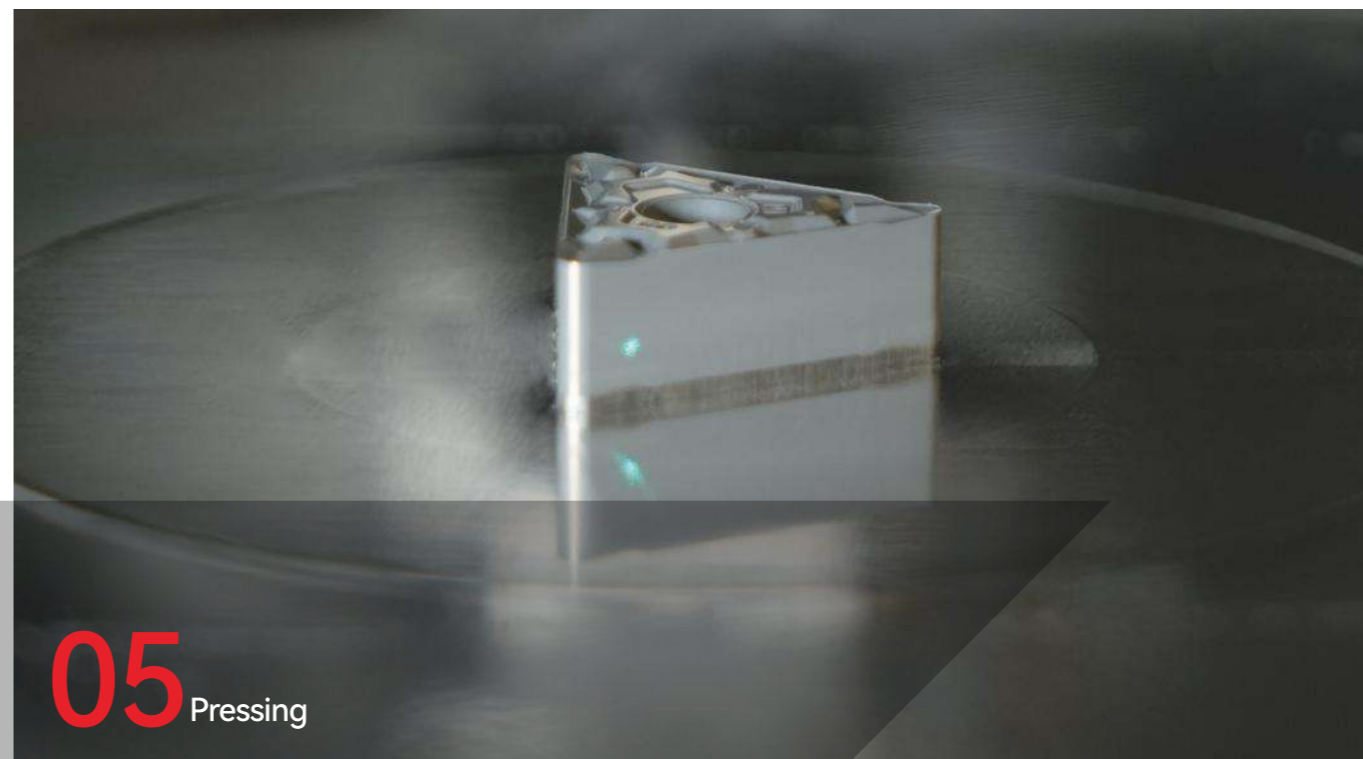

**05** Pressing

06 Sinter HIP



08 Inspection

09 Coating (CVD&PVD)



07 Honing

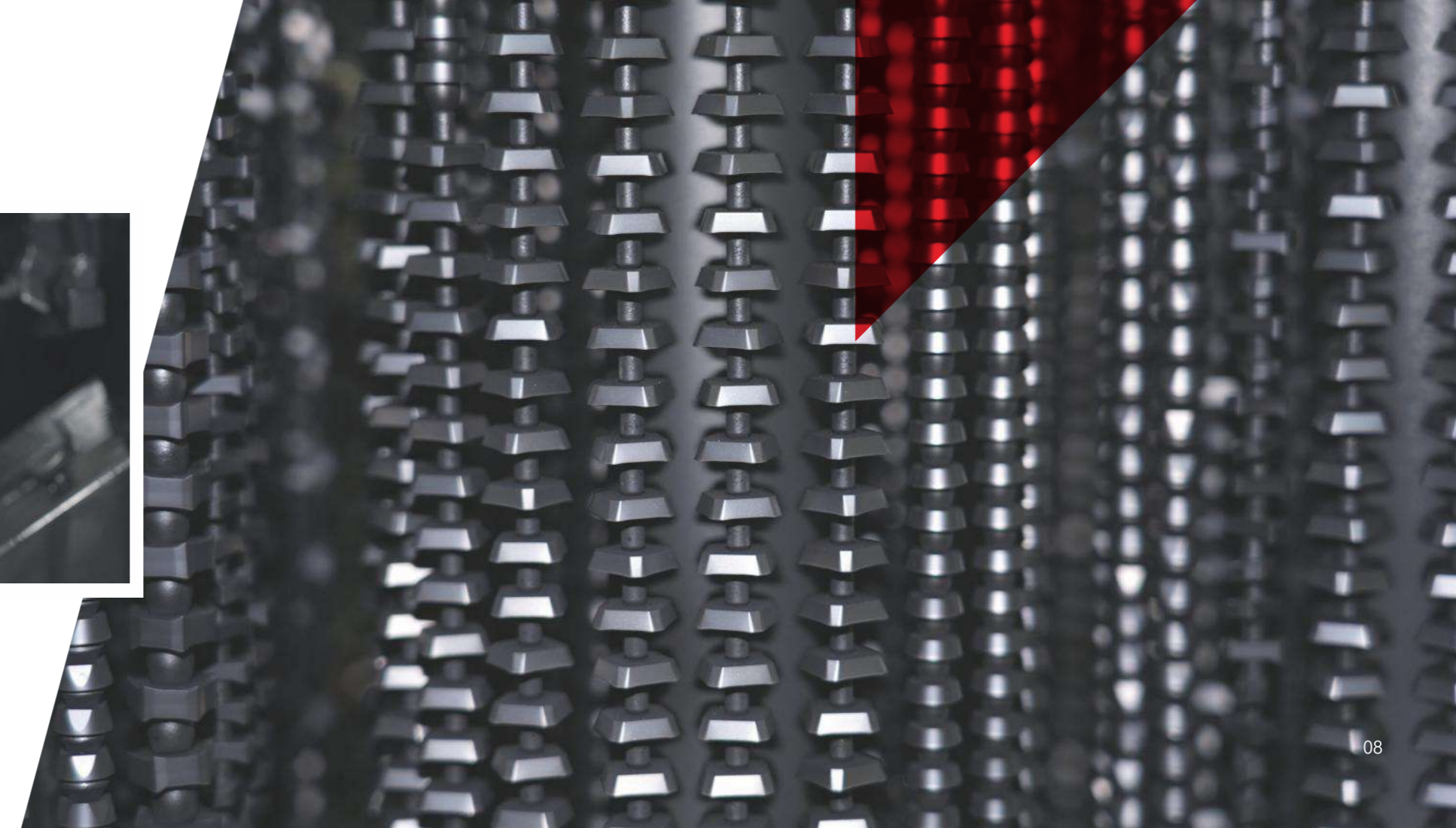

## Main Turning Inserts Chipbreaker

**STEEL**

**Negative PM**

Semi-finishing for Steel and Cast Iron. It has good chip holding, breaking and evacuation performance at high feed speed and deep cutting depth. Sharp cutting edge and low cutting force.

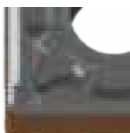

**Positive PM**

Large rake angle and wide cutting edge, ensure a sharp cutting edge while maintaining edge stability during deep cuts. The Y-shaped chipbreaker point ensures smooth chip flow. Suitable for rough to semi-finish turning of steel inner bores.



**Negative PF**

Large inclination and wavy side cutting edge, ensure a sharp cutting edge and have good chip breaking ability and low cutting resistance. Suitable for finishing of steel.

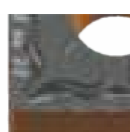

**Positive PF**

A high positive rake angle combined with a flat cutting edge design ensures a sharp cutting edge while delivering excellent chipbreaker performance and low cutting resistance.



**Negative PH**

For heavy duty. Large rake angle meets the sharpness and strength requirements, wavy side cutting edge reduces the cutting resistance, Y-shaped protrusion on the tip improves the chip handling ability.

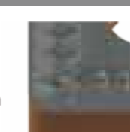

**Positive HF**

Large rake angle and large chipbreaker, smooth chip removal rates. Suitable for semi-finishing to finishing of steel.



**STAINLESS STEEL**

**Negative MM**

Medium-duty chipbreaker geometry for stainless steel machining. The cutting edge design balances sharpness and strength, offering a wide application range. It features low cutting forces and excellent chip evacuation performance.



**Negative MQ**

Large rake angle side edge combined with a double rake angle design provides a sharp cutting edge. The points are positioned forward to ensure smooth chip breaking and reduced cutting resistance. Suitable for stainless steel finishing to semi-finishing.



**Negative MF**

MF suitable for semi finishing and finishing of stainless steel.

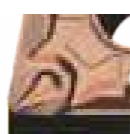

**Positive MM**

Finishing and Semi-finishing Chipbreaker for Common Steel, Alloy Steel and Stainless Steel. With sharp cutting edge, it has excellent machining performance at low cutting depth and feed.



**CAST IRON**

**Negative KM**

Semi-finishing chipbreaker for cast iron, which also can be used for roughing of steel.



**Positive KM**

Semi-finishing for Cast Iron and Steel. Simple general chipbreaker can be used widely.



**Negative CK**

Chipbreaker for Grey Cast Iron, Nodular Cast Iron and Other Cast Iron.



**HIGH HARDNESS MATERIALS**

**Negative MH**

The sharp cutting edge combined with the forward chipbreaker point ensures smooth chip flow during shallow cuts and small feeds, reducing chip wrapping around the workpiece and insert. Suitable for finishing quenched steel after heat treatment.

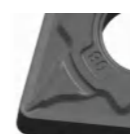

**PARTING & GROOVING**

**Parting & Grooving GM**

Suitable for general machining for parting & grooving.



## Main Milling and Drilling Inserts Chipbreaker

**Milling CM**

Suitable for general milling under semi-finishing cutting condition.

**Milling CR**

Suitable for general roughing under roughing cutting condition.

**Drilling DG**

DG suitable for general drilling under common cutting condition.

## Application Arrange of Chipbreaker

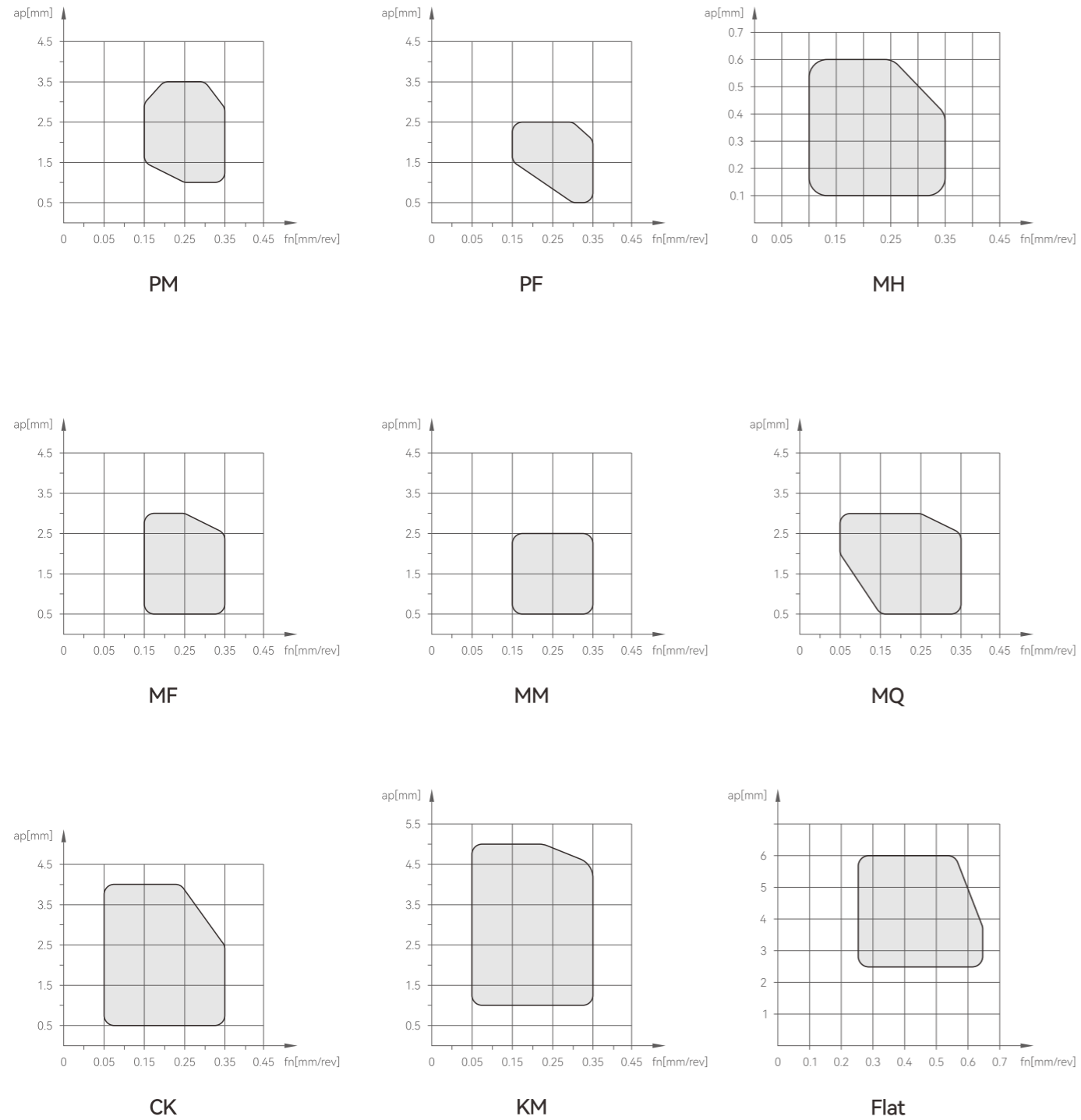



## Grade Chart

### TURNING

Application Classification	General Grade	Features	Application
Steel	CP8115S <sup>NEW</sup>	Manufactured with coarse-grain powder and an advanced sintering process. Features a newly upgraded Al <sub>2</sub> O <sub>3</sub> and MT-TiCN coating system, delivering excellent wear resistance and superior thermal insulation to prevent premature failure caused by high cutting temperatures. Enhanced coating adhesion ensures a denser internal microstructure and improved overall reliability. A CP8115 variant with a full yellow appearance is also available.	Suitable for finishing to semi-finishing of steel and alloy steel under continuous and stable cutting conditions, while also delivering excellent performance in light interrupted operations.
	CP8125S <sup>NEW</sup>	A functionally graded substrate with high binder phase content, combined with columnar Al <sub>2</sub> O <sub>3</sub> and MT-TiCN coatings, provides an optimal balance of toughness and wear resistance. A CP8125 variant with a full yellow appearance is also available.	Offers a wide application range, suitable for medium to rough machining of steel components, with excellent performance under unstable cutting conditions.
	CP8035S	Incorporates an ultra-thick cobalt-enriched toughening layer, providing high substrate strength. Combined with dense, ultra-fine Al <sub>2</sub> O <sub>3</sub> and MT-TiCN coatings for enhanced wear resistance and overall performance.	Suitable for semi-finishing to roughing of steel and alloy steel under interrupted cutting conditions.
Stainless Steel	CM7115A	An ultra-fine grain cemented carbide substrate combined with a nano-structured composite coating delivers outstanding wear resistance and excellent hot hardness at elevated temperatures.	Suitable for machining stainless steel, heat-resistant alloys, and titanium alloys under stable cutting conditions.
	CM7125A	A nano-structured AlTiN coating combined with a substrate featuring high hot hardness and strong resistance to plastic deformation provides excellent high-temperature oxidation resistance and superior anti-adhesive wear performance.	Suitable for low to medium-speed general machining of steel and stainless steel.
	CM7215	Nano-gradient TiAlN/TiSiN coating with excellent resistance to built-up edge (BUE), superior heat resistance, and outstanding oxidation resistance. Micro fine-grain cemented carbide substrate offering high wear resistance and strong impact toughness. The coating is tightly bonded to the substrate, making it suitable for stainless steel finishing to semi-finishing applications.	Suitable for high-speed semi-finishing to light roughing under stable cutting conditions.
	CM7220 <sup>NEW</sup>	An ultra-fine grain carbide substrate combined with a newly engineered coating architecture. The optimized coating composition enhances hardness and wear resistance, improves high-temperature stability, reduces the coefficient of friction, and strengthens chemical stability.	Suitable for high-speed general machining from roughing to finishing under stable cutting conditions. Typical applications include valve bodies and fluid components, food processing machinery, automotive parts, pipe fittings and connectors, marine components, hydraulic parts, construction machinery, general mechanical long-shaft components, decorative parts, and household equipment components.

## TURNING

Application Classification	General Grade	Features	Application
Cast Iron	CK6105 	A high wear-resistant carbide substrate combined with thick MT-TiCN and Al <sub>2</sub> O <sub>3</sub> coatings provides excellent overall wear resistance.	Suitable for high-speed machining of cast iron.
	CK6115 	A high-toughness carbide substrate combined with columnar MT-TiCN and Al <sub>2</sub> O <sub>3</sub> coatings delivers excellent wear resistance and outstanding impact resistance.	Suitable for semi-finishing to roughing of gray cast iron and ductile cast iron under various interrupted cutting conditions.
High Hardness Materials	CH3005	A nano-crystalline carbide substrate combined with a specially engineered PVD Al <sub>2</sub> O <sub>3</sub> composite coating process provides excellent high-temperature performance. It maintains stable mechanical properties under elevated temperatures, preventing deformation or premature failure caused by thermal stress. It delivers superior surface finish quality, enabling turning to replace grinding operations.	Suitable for finishing of hardened materials with hardness ranging from HRC 50–63 after heat treatment. Widely applied across various industries, including mold and die manufacturing for machining high-hardness tool steels; automotive manufacturing for hardened components; as well as aerospace, energy, and medical device industries.

## MILLING

Application Classification	General Grade	Features	Application
High Hardness Materials	CH5005	Utilizes a nano-structured carbide substrate with extremely high hardness and transverse rupture strength. Special edge-strengthening treatment reduces cutting forces while maintaining high edge strength. A PVD Al <sub>2</sub> O <sub>3</sub> composite coating provides excellent high-temperature resistance and thermal stability.	Suitable for finishing of hardened materials with hardness ranging from HRC 50 after heat treatment. Widely applied in industries requiring high strength and hardness, such as automotive components, mold and die manufacturing, and machine tool accessories.
	CA5105	An ultra-fine grain substrate combined with a high-temperature resistant coating delivers superior wear resistance and improved chipping resistance compared with conventional grades.	Specially developed for hard materials (HRC 38–50), primarily applied in the mold and die industry. Suitable for machining heat-treated tool steels, high-hardness materials, high-temperature alloys, and cast iron.
General Use	CA5120	A nano-structured AlTiN coating combined with a substrate featuring high hot hardness and strong resistance to plastic deformation provides excellent high-temperature oxidation resistance and superior resistance to adhesive wear.	Suitable for general milling of steel, stainless steel, and similar materials.
	CA5125	The AlCrN coating provides high wear resistance.	Suitable for general milling of steel and standard carbon steel.
Cast Iron	CK6020	A specially engineered carbide substrate combined with thick MT-TiCN and Al <sub>2</sub> O <sub>3</sub> coatings provides excellent high-temperature oxidation resistance and superior resistance to adhesive wear.	Suitable for milling of cast iron and similar materials.

## DRILLING

Application Classification	General Grade	Features	Application
High Hardness Materials	CA5105	An ultra-fine grain substrate combined with a high-temperature resistant coating offers superior wear resistance and enhanced chipping resistance compared to conventional grades.	Specially developed for hard materials (HRC 38–50), primarily applied in the mold and die industry. Suitable for machining heat-treated tool steels, high-hardness materials, high-temperature alloys, and cast iron.
Stainless Steel	CA5110	An ultra-fine grain carbide substrate combined with a nano-structured composite coating delivers excellent wear resistance and outstanding hot hardness at elevated temperatures.	Suitable for machining of stainless steel, heat-resistant alloy, titanium alloy and other difficult to machine materials under stable cutting conditions.
Steel	CA5120	A nano-structured AlTiN coating combined with a substrate featuring high hot hardness and strong resistance to plastic deformation provides excellent high-temperature oxidation resistance and superior resistance to adhesive wear.	Suitable for general milling of steel, stainless steel and other materials.

## CERMET

Application Classification	General Grade	Features	Application
Cermets	CMT55	A fine-grain, high-titanium carbide grade featuring high hardness, excellent wear resistance, and good toughness. Suitable for high-speed and light interrupted machining, delivering superior surface finish quality and high cutting efficiency.	Suitable for continuous and light interrupted machining of steel and stainless steel, as well as parting and grooving operations.
	CMT80A	A fine-grain grade with a higher binder phase content, offering high toughness and strong impact resistance. It provides good thermal stability and wear resistance, with excellent versatility across a wide range of cutting applications.	Suitable for continuous and light interrupted machining of steel and stainless steel, as well as parting and grooving operations. Widely applied in the bearing manufacturing industry.
	CP55TM 	A high-toughness, wear-resistant substrate coated with TiAlN/TiN PVD coating provides excellent wear resistance and oxidation resistance. Suitable for high-speed, light interrupted, long-life and stable machining, delivering superior surface finish quality and high cutting efficiency.	Suitable for continuous and light interrupted machining of steel and stainless steel, as well as parting and grooving operations.
	CP80TM	A high-toughness, wear-resistant substrate coated with a TiAlN/TiN PVD layer offers excellent wear and oxidation resistance. It is suitable for high-speed, light interrupted, long-life stable machining, delivering superior surface finish and high cutting efficiency.	Suitable for continuous and light interrupted machining of steel and stainless steel, as well as parting and grooving operations.

## Turning Inserts

- ▶ Turning Insert Code System (ISO)
- ▶ Negative Turning Inserts
- ▶ Positive turning inserts

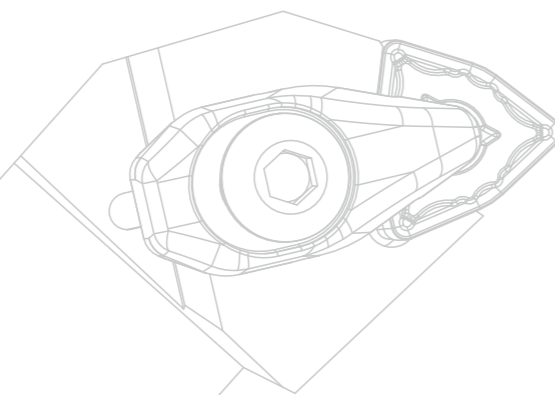

# A

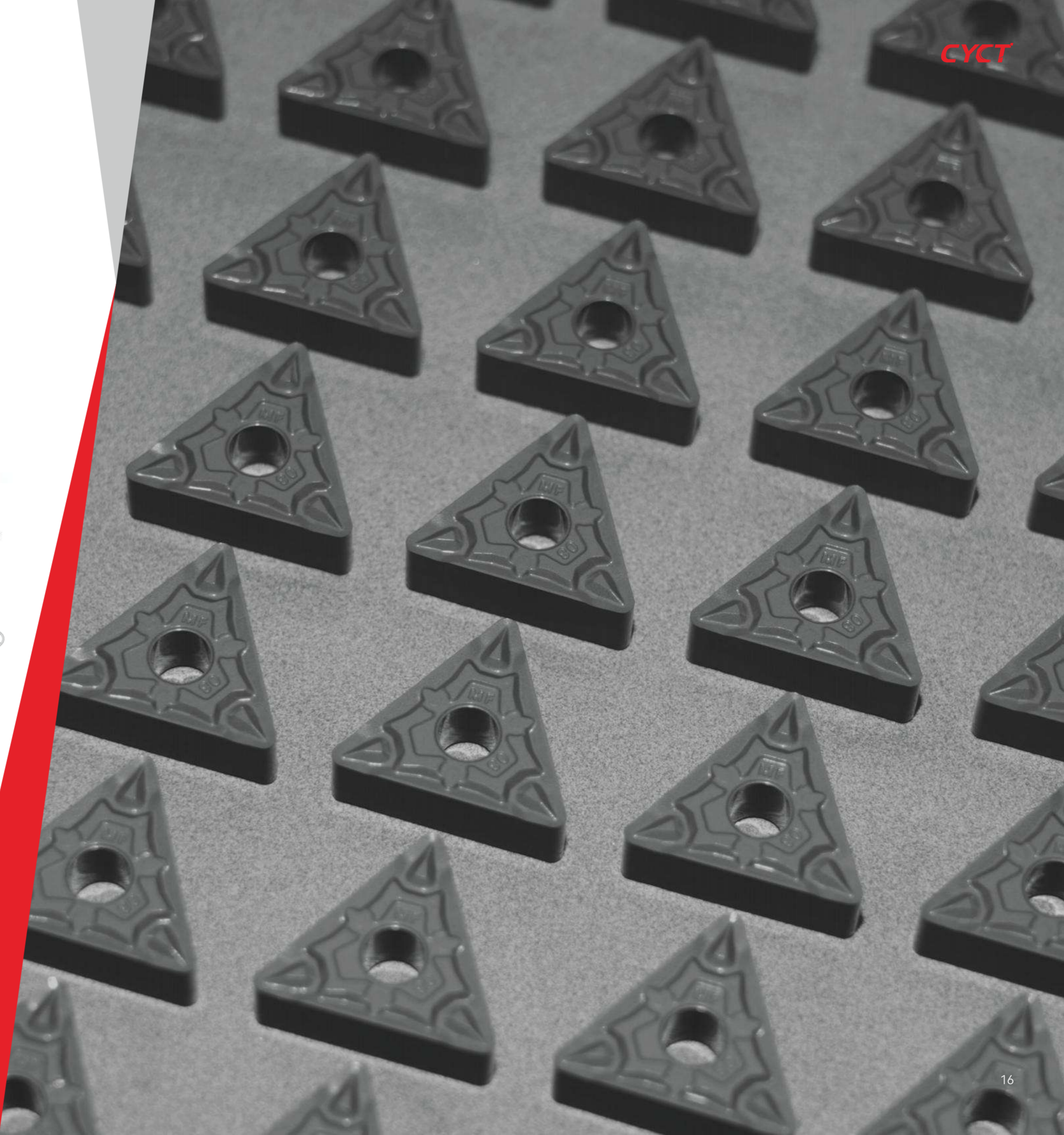

### Turning Insert Code System (ISO)

Code	Relief Angle	Code	Hole	Chipbreaker	Section Sketch	Code	Hole	Chipbreaker	Section Sketch
<b>A</b>	3°	<b>B</b>	Y	N		<b>N</b>	N	N	
<b>B</b>	5°	<b>H</b>	Y	Single Side		<b>R</b>	N	Single Side	
<b>C</b>	7°	<b>C</b>	Y	N		<b>F</b>	N	Double Side	
<b>D</b>	15°	<b>J</b>	Y	Double Side		<b>A</b>	Y	N	
<b>E</b>	20°	<b>W</b>	Y	N		<b>M</b>	Y	Single Side	
<b>F</b>	25°	<b>T</b>	Y	Single Side		<b>G</b>	Y	Double Side	
<b>G</b>	30°	<b>Q</b>	Y	N		<b>X</b>	---	---	Special
<b>N</b>	0°	<b>U</b>	Y	Double Side					
<b>P</b>	11°								
<b>O</b>	Others								

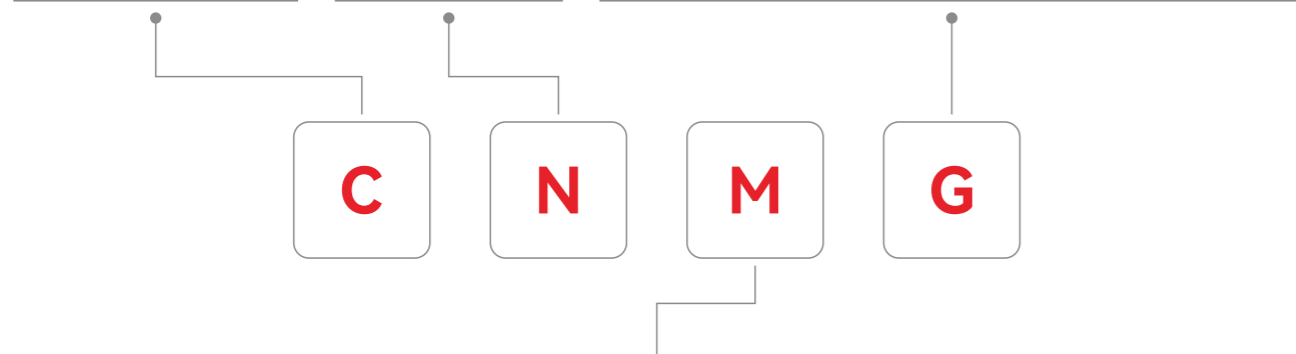

Tolerance							
Code	Cutting Point Height (mm)	Inscribed Circle $\Phi$ Tol.	Thickness Tol.(mm)	• Cutting Point Height (mm) Tolerance			
<b>A</b>	±0.005	±0.025	±0.025	Inscribed Circle Equilateral Triangle Square 80° Rhomb 55° Rhomb 35° Rhomb Round			
<b>F</b>	±0.005	±0.013	±0.025	6.35 ±0.08 ±0.08 ±0.08 ±0.11 ±0.16 ---			
<b>C</b>	±0.013	±0.025	±0.025	9.525 ±0.08 ±0.08 ±0.08 ±0.11 ±0.16 ---			
<b>H</b>	±0.013	±0.013	±0.025	12.7 ±0.13 ±0.13 ±0.13 ±0.15 --- ---			
<b>E</b>	±0.025	±0.025	±0.025	15.875 ±0.15 ±0.15 ±0.15 ±0.18 --- ---			
<b>G</b>	±0.025	±0.025	±0.13	19.05 ±0.15 ±0.15 ±0.15 ±0.18 --- ---			
<b>J</b>	±0.005	±0.05~±0.13	±0.025	25.4 --- ±0.18 --- --- ---			
<b>K</b>	±0.013	±0.05~±0.13	±0.025	• Inscribed Circular $\Phi$ Tolerance			
<b>L</b>	±0.025	±0.05~±0.13	±0.025	Inscribed Circle Equilateral Triangle Square 80° Rhomb 55° Rhomb 35° Rhomb Round			
<b>M</b>	±0.08~±0.18	±0.05~±0.13	±0.13	6.35 ±0.05 ±0.05 ±0.05 ±0.05 ±0.05 ±0.05 ---			
<b>N</b>	±0.08~±0.18	±0.05~±0.13	±0.025	9.525 ±0.05 ±0.05 ±0.05 ±0.05 ±0.05 ±0.05 ---			
<b>U</b>	±0.13~±0.38	±0.08~±0.25	±0.13	12.7 ±0.08 ±0.18 ±0.08 ±0.08 --- ---			
				15.875 ±0.10 ±0.10 ±0.10 ±0.10 --- ---			
				19.05 ±0.10 ±0.10 ±0.10 ±0.10 --- ---			
				25.4 --- ±0.13 --- --- ---			

Inscribed Circle Diameter (mm)	Inserts Shape							
	C	D	R	S	T	V	W	K
3.97					6			
5.5			5					
5.56					9			
6			6					
6.35	6	7			11	11		
8			8					
9.525	9	11	9	9	16	16	6	16
10			10					
12			12					
12.7	12	15	12	12	22	22	8	
15.875	16		15	15	27			
16		19	16					
19.05	19		19	19	33			
20		25	20					
25	25		25					
25.4			25	25	25			
31.75			31	32	32			
32			32					

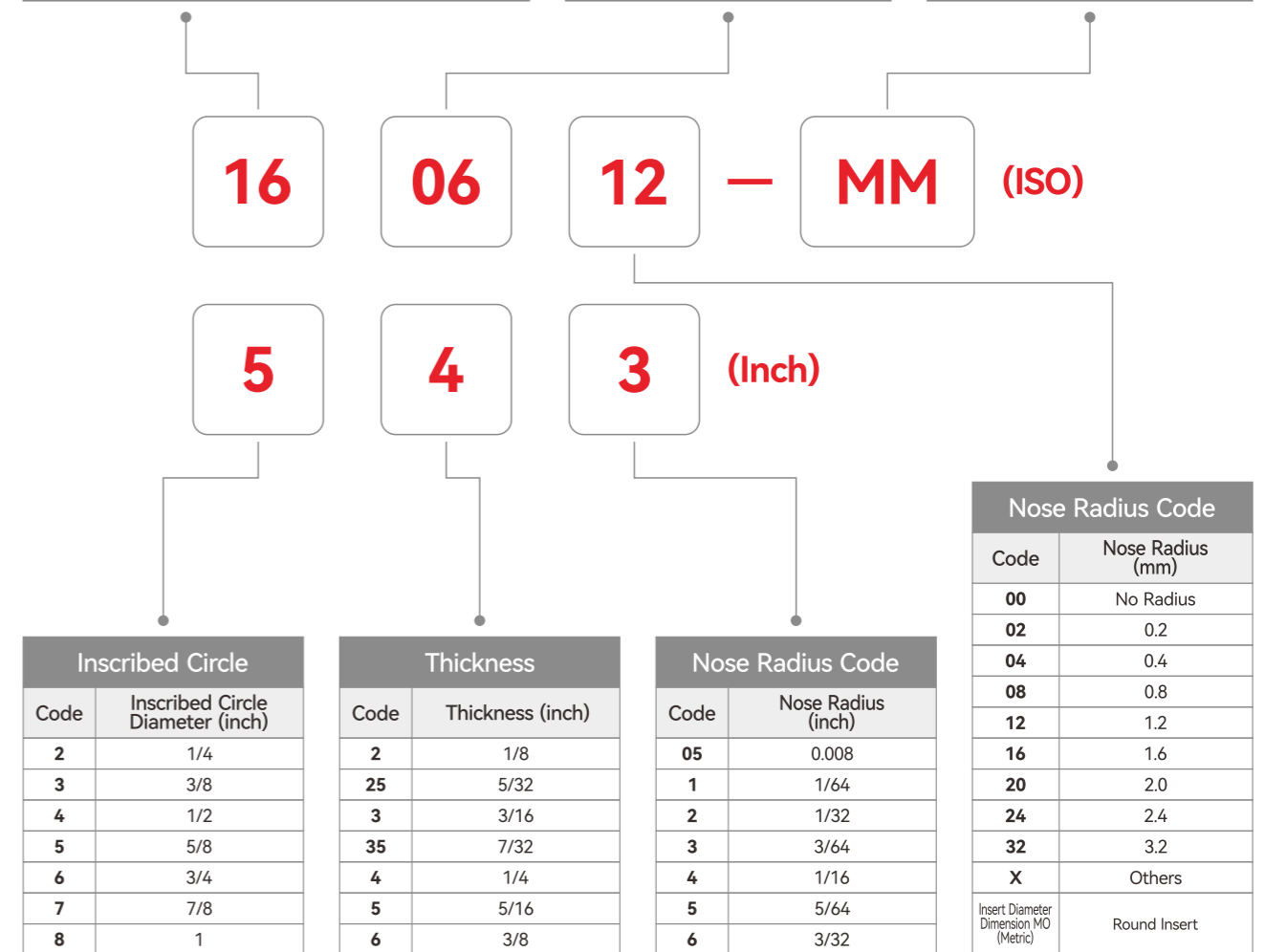

Inscribed Circle	
Code	Inscribed Circle Diameter (inch)
2	1/4
3	3/8
4	1/2
5	5/8
6	3/4
7	7/8
8	1

Thickness	
Code	Thickness (inch)
2	1/8
25	5/32
3	3/16
35	7/32
4	1/4
5	5/16
6	3/8

Nose Radius Code	
Code	Nose Radius (inch)
05	0.008
1	1/64
2	1/32
3	3/64
4	1/16
5	5/64
6	3/32

Nose Radius Code	
Code	Nose Radius (mm)
00	No Radius
02	0.2
04	0.4
08	0.8
12	1.2
16	1.6
20	2.0
24	2.4
32	3.2
X	Others
Insert Diameter Dimension MO (Metric)	Round Insert

### Negative Turning Inserts

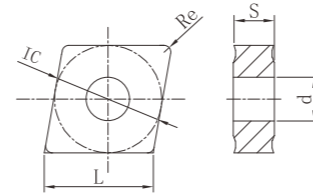

Shape	Type	Basic Dimension (mm)					P					M				K	H		
		L	IC	S	d	Re	CP8115	CP8115S	CP8125	CP8125S	CP8025H	CP8035S	CM7115A	CM7125A	CM7215	CM7220	CK6105	CK6115	CH3005
	CNMG120404-PM	12.9	12.7	4.76	5.16	0.4	○	○	○	●	○								
	CNMG120408-PM	12.9	12.7	4.76	5.16	0.8	○	○	○	●	○								
	CNMG120412-PM	12.9	12.7	4.76	5.16	1.2	○	○	○	●	○								
	CNMG120416-PM	12.9	12.7	4.76	5.16	1.6	○	○	○	●	○								
	CNMG160608-PM	16.1	15.875	6.35	6.35	0.8	○	○	○	●	○								
	CNMG160612-PM	16.1	15.875	6.35	6.35	1.2	○	○	○	●	○								
	CNMG160616-PM	16.1	15.875	6.35	6.35	1.6	○	○	○	●	○								
	CNMG190608-PM	19.3	19.05	6.35	6.35	0.8	○	○	○	●	○								
	CNMG190612-PM	19.3	19.05	6.35	6.35	1.2	○	○	○	●	○								
	CNMG190616-PM	19.3	19.05	6.35	6.35	1.6	○	○	○	●	○								
	CNMG120404-PF	12.9	12.7	4.76	5.16	0.4	○	●	○	○									
	CNMG120408-PF	12.9	12.7	4.76	5.16	0.8	○	●	○	○									
	CNMG160604-PF	16.1	15.875	6.35	6.35	0.4	○	●	○	○									
	CNMG160608-PF	16.1	15.875	6.35	6.35	0.8	○	●	○	○									
	CNMG190608-PF	19.3	19.05	6.35	6.35	0.8	○	●	○	○									
	CNMG190612-PF	19.3	19.05	6.35	6.35	1.2	○	●	○	○									
	CNMG120404-MM	12.9	12.7	4.76	5.16	0.4						●	●	○	○				
	CNMG120408-MM	12.9	12.7	4.76	5.16	0.8						●	●	○	○				
	CNMG120412-MM	12.9	12.7	4.76	5.16	1.2						●	●	○	○				
	CNMG120404-MQ	12.9	12.7	4.76	5.16	0.4						○	○	●	●				
	CNMG120408-MQ	12.9	12.7	4.76	5.16	0.8						○	○	●	●				
	CNMG120404-MF	12.9	12.7	4.76	5.16	0.4						○	○	●	●				
	CNMG120408-MF	12.9	12.7	4.76	5.16	0.8						○	○	●	●				
	CNMG120404-SM	12.9	12.7	4.76	5.16	0.4						●	○	●	○				
	CNMG120408-SM	12.9	12.7	4.76	5.16	0.8						●	○	●	○				
	CNMG120412-SM	12.9	12.7	4.76	5.16	1.2						●	○	●	○				
	CNMG120416-SM	12.9	12.7	4.76	5.16	1.6						●	○	●	○				
	CNMG160608-SM	16.1	15.875	6.35	6.35	0.8						●	○	●	○				
	CNMG160612-SM	16.1	15.875	6.35	6.35	1.2						●	○	●	○				
	CNMG160616-SM	16.1	15.875	6.35	6.35	1.6						●	○	●	○				
	CNMG190608-SM	19.3	19.05	6.35	7.94	0.8						●	○	●	○				
	CNMG190612-SM	19.3	19.05	6.35	7.94	1.2						●	○	●	○				
	CNMG190616-SM	19.3	19.05	6.35	7.94	1.6						●	○	●	○				

● Ready Stock ○ Available for Production

### Negative Turning Inserts

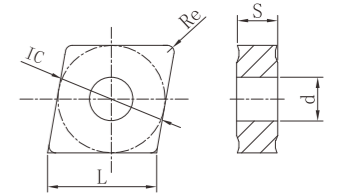

Shape	Type	Basic Dimension (mm)					P					M				K	H		
		L	IC	S	d	Re	CP8115	CP8115S	CP8125	CP8125S	CP8025H	CP8035S	CM7115A	CM7125A	CM7215	CM7220	CK6105	CK6115	CH3005
	CNMG120404-KM	12.9	12.7	4.76	5.16	0.4												●	○
	CNMG120408-KM	12.9	12.7	4.76	5.16	0.8												●	○
	CNMG120412-KM	12.9	12.7	4.76	5.16	1.2												●	○
	CNMG160608-KM	16.1	15.875	6.35	6.35	0.8												●	○
	CNMG160612-KM	16.1	15.875	6.35	6.35	1.2												●	○
	CNMG160616-KM	16.1	15.875	6.35	6.35	1.6												●	○
	CNMG190608-KM	19.3	19.05	6.35	7.94	0.8												●	○
	CNMG190612-KM	19.3	19.05	6.35	7.94	1.2												●	○
	CNMG190616-KM	19.3	19.05	6.35	7.94	1.6												●	○
		CNMG120404-CK	12.9	12.7	4.76	5.16	0.4												○
CNMG120408-CK		12.9	12.7	4.76	5.16	0.8												○	●
CNMG120412-CK		12.9	12.7	4.76	5.16	1.2												○	●
CNMG160608-CK		16.1	15.875	6.35	6.35	0.8												○	●
CNMG160612-CK		16.1	15.875	6.35	6.35	1.2												○	●
CNMG160616-CK		16.1	15.875	6.35	6.35	1.6												○	●
	CNMA120404	12.9	12.7	4.76	5.16	0.4												○	●
	CNMA120408	12.9	12.7	4.76	5.16	0.8												○	●
	CNMA120412	12.9	12.7	4.76	5.16	1.2												○	●
	CNMA160608	16.1	15.875	6.35	6.35	0.8												○	●
	CNMA160612	16.1	15.875	6.35	6.35	1.2												○	●
	CNMA160616	16.1	15.875	6.35	6.35	1.6												○	●
	CNMA190608	19.3	19.05	6.35	7.94	0.8												○	●
	CNMA190612	19.3	19.05	6.35	7.94	1.2												○	●
	CNMA190616	19.3	19.05	6.35	7.94	1.6												○	●

● Ready Stock ○ Available for Production

### Negative Turning Inserts

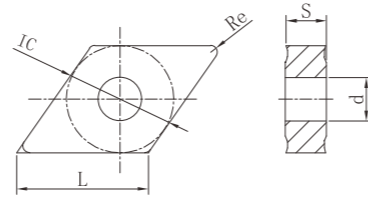

Shape	Type	Basic Dimension (mm)					P					M				K	H		
		L	IC	S	d	Re	CP8115	CP8115S	CP8125	CP8125S	CP8025H	CP8035S	CM7115A	CM7125A	CM7215	CM7220	CK6105	CK6115	CH3005
	DNMG110404-PM	11.6	9.525	4.76	3.81	0.4	○	○	○	●	○	○							
	DNMG110408-PM	11.6	9.525	4.76	3.81	0.8	○	○	○	●	○	○							
	DNMG150404-PM	15.5	12.7	4.76	5.16	0.4	○	○	○	●	○	○							
	DNMG150408-PM	15.5	12.7	4.76	5.16	0.8	○	○	○	●	○	○							
	DNMG150604-PM	15.5	12.7	6.35	5.16	0.4	○	○	○	●	○	○							
	DNMG150608-PM	15.5	12.7	6.35	5.16	0.8	○	○	○	●	○	○							
	DNMG150612-PM	15.5	12.7	6.35	5.16	1.2	○	●	○	○	○	○							
	DNMG150404-PF	15.5	12.7	4.76	5.16	0.4	○	●	○	○									
	DNMG150408-PF	15.5	12.7	4.76	5.16	0.8	○	●	○	○									
	DNMG150604-PF	15.5	12.7	6.35	5.16	0.4	○	●	○	○									
	DNMG150608-PF	15.5	12.7	6.35	5.16	0.8	○	●	○	○									
	DNMG150612-PF	15.5	12.7	6.35	5.16	1.2	○	●	○	○									
	DNMG110404-MM	11.6	9.525	4.76	3.81	0.4							●	●	○	○			
	DNMG110408-MM	11.6	9.525	4.76	3.81	0.8							●	●	○	○			
	DNMG150404-MM	15.5	12.7	4.76	5.16	0.4							●	●	○	○			
	DNMG150408-MM	15.5	12.7	4.76	5.16	0.8							●	●	○	○			
	DNMG150412-MM	15.5	12.7	4.76	5.16	1.2							●	●	○	○			
	DNMG150604-MM	15.5	12.7	6.35	5.16	0.4							●	●	○	○			
	DNMG150608-MM	15.5	12.7	6.35	5.16	0.8							●	●	○	○			
	DNMG150612-MM	15.5	12.7	6.35	5.16	1.2							●	●	○	○			
	DNMG150404-MQ	15.5	12.7	4.76	5.16	0.4							○	○	●	●			
	DNMG150408-MQ	15.5	12.7	4.76	5.16	0.8							○	○	●	●			
	DNMG150412-MQ	15.5	12.7	4.76	5.16	1.2							○	○	●	●			
	DNMG150604-MQ	15.5	12.7	6.35	5.16	0.4							○	○	●	●			
	DNMG150608-MQ	15.5	12.7	6.35	5.16	0.8							○	○	●	●			
	DNMG150612-MQ	15.5	12.7	6.35	5.16	1.2							○	○	●	●			
	DNMG110404-MF	11.6	9.525	4.76	3.81	0.4							○	○	●	●			
	DNMG110408-MF	11.6	9.525	4.76	3.81	0.8							○	○	●	●			
	DNMG150404-MF	15.5	12.7	4.76	5.16	0.4							○	○	●	●			
	DNMG150408-MF	15.5	12.7	4.76	5.16	0.8							○	○	●	●			
	DNMG150604-MF	15.5	12.7	6.35	5.16	0.4							○	○	●	●			
	DNMG150608-MF	15.5	12.7	6.35	5.16	0.8							○	○	●	●			

● Ready Stock ○ Available for Production

### Negative Turning Inserts

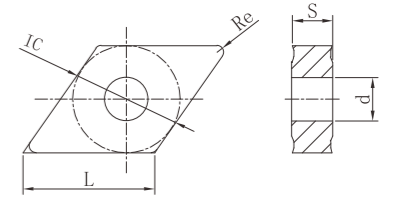

Shape	Type	Basic Dimension (mm)					P					M				K	H	
		L	IC	S	d	Re	CP8115	CP8115S	CP8125	CP8125S	CP8025H	CP8035S	CM7115A	CM7125A	CM7215	CM7220	CK6105	CK6115
	DNMG110404-SM	11.6	9.525	4.76	3.81	0.4							●	○	●	○		
	DNMG110408-SM	11.6	9.525	4.76	3.81	0.8							●	○	●	○		
	DNMG110412-SM	11.6	9.525	4.76	3.81	1.2							●	○	●	○		
	DNMG150404-SM	15.5	12.7	4.76	5.16	0.4							●	○	●	○		
	DNMG150408-SM	15.5	12.7	4.76	5.16	0.8							●	○	●	○		
	DNMG150412-SM	15.5	12.7	4.76	5.16	1.2							●	○	●	○		
	DNMG150604-SM	15.5	12.7	6.35	5.16	0.4							●	○	●	○		
	DNMG150608-SM	15.5	12.7	6.35	5.16	0.8							●	○	●	○		
	DNMG150612-SM	15.5	12.7	6.35	5.16	1.2							●	○	●	○		
	DNMG110404-KM	11.6	9.525	4.76	3.81	0.4											●	○
	DNMG110408-KM	11.6	9.525	4.76	3.81	0.8											●	○
	DNMG150404-KM	15.5	12.7	4.76	5.16	0.4											●	○
	DNMG150408-KM	15.5	12.7	4.76	5.16	0.8											●	○
	DNMG150412-KM	15.5	12.7	4.76	5.16	1.2											●	○
	DNMG150604-KM	15.5	12.7	6.35	5.16	0.4											●	○
	DNMG150608-KM	15.5	12.7	6.35	5.16	0.8											●	○
	DNMG150612-KM	15.5	12.7	6.35	5.16	1.2											●	○
	DNMG110404-CK	11.6	9.525	4.76	3.81	0.4											○	●
	DNMG110408-CK	11.6	9.525	4.76	3.81	0.8											○	●
	DNMG150404-CK	15.5	12.7	4.76	5.16	0.4											○	●
	DNMG150408-CK	15.5	12.7	4.76	5.16	0.8											○	●
	DNMG150412-CK	15.5	12.7	4.76	5.16	1.2											○	●
	DNMA150404	15.5	12.7	4.76	5.16	0.4											○	●
	DNMA150408	15.5	12.7	4.76	5.16	0.8											○	●
	DNMA150412	15.5	12.7	4.76	5.16	1.2											○	●
	DNMA150604	15.5	12.7	6.35	5.16	0.4											○	●
	DNMA150608	15.5	12.7	6.35	5.16	0.8											○	●
	DNMA150612	15.5	12.7	6.35	5.16	1.2											○	●

● Ready Stock ○ Available for Production

### Negative Turning Inserts

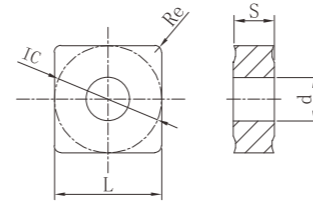

Shape	Type	Basic Dimension (mm)					P					M				K	H		
		L	IC	S	d	Re	CP8115	CP8115S	CP8125	CP8125S	CP8025H	CP8035S	CM7115A	CM7125A	CM7215	CM7220	CK6105	CK6115	CH3005
	SNMG120404-PM	12.7	12.7	4.76	5.16	0.4	○	○	○	●	○								
	SNMG120408-PM	12.7	12.7	4.76	5.16	0.8	○	○	○	●	○								
	SNMG120412-PM	12.7	12.7	4.76	5.16	1.2	○	○	○	●	○								
	SNMG120416-PM	12.7	12.7	4.76	5.16	1.6	○	○	○	●	○								
	SNMG150608-PM	15.875	15.875	6.35	6.35	0.8	○	○	○	●	○								
	SNMG150612-PM	15.875	15.875	6.35	6.35	1.2	○	○	○	●	○								
	SNMG190612-PM	19.05	19.05	6.35	7.94	1.2	○	○	○	●	○								
	SNMG190616-PM	19.05	19.05	6.35	7.94	1.6	○	○	○	●	○								
	SNMG120404-PF	12.7	12.7	4.76	5.16	0.4	○	●	○	○									
	SNMG120408-PF	12.7	12.7	4.76	5.16	0.8	○	●	○	○									
	SNMG150608-PF	15.875	15.875	6.35	6.35	0.8	○	●	○	○									
	SNMG150612-PF	15.875	15.875	6.35	6.35	1.2	○	●	○	○									
	SNMG190604-PF	19.05	19.05	6.35	7.94	0.4	○	●	○	○									
SNMG190608-PF	19.05	19.05	6.35	7.94	0.8	○	●	○	○										
	SNMM250724-PH	25.4	25.4	7.94	9.12	2.4			●	●	○								
	SNMM250924-PH	25.4	25.4	9.52	9.12	2.4			●	●	○								
	SNMG120404-MM	12.7	12.7	4.76	5.16	0.4						●	○	●	○				
	SNMG120408-MM	12.7	12.7	4.76	5.16	0.8						●	○	●	○				
	SNMG120412-MM	12.7	12.7	4.76	5.16	1.2						●	○	●	○				
	SNMG150608-MM	15.875	15.875	6.35	6.35	0.8						●	○	●	○				
	SNMG120404-MQ	12.7	12.7	4.76	5.16	0.4						○	○	●	●				
	SNMG120408-MQ	12.7	12.7	4.76	5.16	0.8						○	○	●	●				
	SNMG120404-MF	12.7	12.7	4.76	5.16	0.4						○	○	●	●				
	SNMG120408-MF	12.7	12.7	4.76	5.16	0.8						○	○	●	●				

● Ready Stock ○ Available for Production

### Negative Turning Inserts

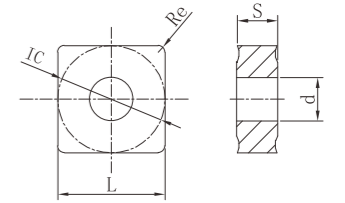

Shape	Type	Basic Dimension (mm)					P					M				K	H		
		L	IC	S	d	Re	CP8115	CP8115S	CP8125	CP8125S	CP8025H	CP8035S	CM7115A	CM7125A	CM7215	CM7220	CK6105	CK6115	CH3005
	SNMG120404-SM	12.7	12.7	4.76	5.16	0.4								●	○	●	○		
	SNMG120408-SM	12.7	12.7	4.76	5.16	0.8								●	○	●	○		
	SNMG120412-SM	12.7	12.7	4.76	5.16	1.2								●	○	●	○		
	SNMG120416-SM	12.7	12.7	4.76	5.16	1.6								●	○	●	○		
	SNMG150608-SM	15.875	15.875	6.35	6.35	0.8								●	○	●	○		
	SNMG150612-SM	15.875	15.875	6.35	6.35	1.2								●	○	●	○		
	SNMG190608-SM	19.05	19.05	6.35	7.94	0.8								●	○	●	○		
	SNMG190612-SM	19.05	19.05	6.35	7.94	1.2								●	○	●	○		
SNMG190616-SM	19.05	19.05	6.35	7.94	1.6								●	○	●	○			
	SNMG120404-KM	12.7	12.7	4.76	5.16	0.4												●	○
	SNMG120408-KM	12.7	12.7	4.76	5.16	0.8												●	○
	SNMG120412-KM	12.7	12.7	4.76	5.16	1.2												●	○
	SNMG150608-KM	15.875	15.875	6.35	6.35	0.8												●	○
	SNMG150612-KM	15.875	15.875	6.35	6.35	1.2												●	○
	SNMG150616-KM	15.875	15.875	6.35	6.35	1.6												●	○
	SNMG190608-KM	19.05	19.05	6.35	7.94	0.8												●	○
	SNMG190612-KM	19.05	19.05	6.35	7.94	1.2												●	○
SNMG190616-KM	19.05	19.05	6.35	7.94	1.6												●	○	
	SNMG120404-CK	12.7	12.7	4.76	5.16	0.4												○	●
	SNMG120408-CK	12.7	12.7	4.76	5.16	0.8												○	●
	SNMG120412-CK	12.7	12.7	4.76	5.16	1.2												○	●
	SNMA120408	12.7	12.7	4.76	5.16	0.8												○	●
	SNMA120412	12.7	12.7	4.76	5.16	1.2												○	●
	SNMA150608	15.875	15.875	6.35	6.35	0.8												○	●
	SNMA150612	15.875	15.875	6.35	6.35	1.2												○	●
	SNMA190608	19.05	19.05	6.35	7.94	0.8												○	●
SNMA190612	19.05	19.05	6.35	7.94	1.2												○	●	
SNMA190616	19.05	19.05	6.35	7.94	1.6												○	●	

● Ready Stock ○ Available for Production

### Negative Turning Inserts

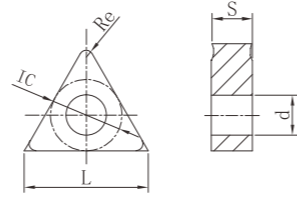

Shape	Type	Basic Dimension (mm)					P					M				K	H		
		L	IC	S	d	Re	CP8115	CP8115S	CP8125	CP8125S	CP8025H	CP8035S	CM7115A	CM7125A	CM7215	CM7220	CK6105	CK6115	CH3005
	TNMG160404-PM	16.5	9.525	4.76	3.81	0.4	○	○	○	●	○								
	TNMG160408-PM	16.5	9.525	4.76	3.81	0.8	○	○	○	●	○								
	TNMG160412-PM	16.5	9.525	4.76	3.81	1.2	○	○	○	●	○								
	TNMG220408-PM	22	12.7	4.76	5.16	0.8	○	○	○	●	○								
	TNMG220412-PM	22	12.7	4.76	5.16	1.2	○	○	○	●	○								
	TNMG220416-PM	22	12.7	4.76	5.16	1.6	○	○	○	●	○								
	TNMG160404-PF	16.5	9.525	4.76	3.81	0.4	○	●	○	○									
	TNMG160408-PF	16.5	9.525	4.76	3.81	0.8	○	●	○	○									
	TNMG220404-PF	22	12.7	4.76	5.16	0.4	○	●	○	○									
	TNMG220408-PF	22	12.7	4.76	5.16	0.8	○	●	○	○									
	TNMG160402-MM	16.5	9.525	4.76	3.81	0.4						●	○	●	○				
	TNMG160404-MM	16.5	9.525	4.76	3.81	0.4						●	○	●	○				
	TNMG160408-MM	16.5	9.525	4.76	3.81	0.8						●	○	●	○				
	TNMG160412-MM	16.5	9.525	4.76	3.81	1.2						●	○	●	○				
	TNMG220404-MM	22	12.7	4.76	5.16	0.4						●	○	●	○				
	TNMG220408-MM	22	12.7	4.76	5.16	0.8						●	○	●	○				
TNMG220412-MM	22	12.7	4.76	5.16	1.2						●	○	●	○					
	TNMG160404-MQ	16.5	9.525	4.76	3.81	0.4						○	○	●	●				
	TNMG160408-MQ	16.5	9.525	4.76	3.81	0.8						○	○	●	●				
	TNMG160404-MF	16.5	9.525	4.76	3.81	0.4						○	○	●	●				
	TNMG160408-MF	16.5	9.525	4.76	3.81	0.8						○	○	●	●				
	TNMG160404-SM	16.5	9.525	4.76	3.81	0.4						●	○	●	○				
	TNMG160408-SM	16.5	9.525	4.76	3.81	0.8						●	○	●	○				
	TNMG160412-SM	16.5	9.525	4.76	3.81	1.2						●	○	●	○				
	TNMG220408-SM	22	12.7	4.76	5.16	0.8						●	○	●	○				
	TNMG220412-SM	22	12.7	4.76	5.16	1.2						●	○	●	○				
	TNMG220416-SM	22	12.7	4.76	5.16	1.6						●	○	●	○				

● Ready Stock ○ Available for Production

### Negative Turning Inserts

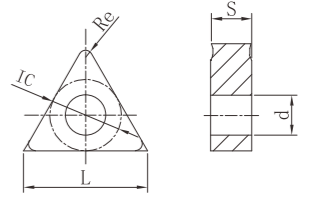

Shape	Type	Basic Dimension (mm)					P					M				K	H		
		L	IC	S	d	Re	CP8115	CP8115S	CP8125	CP8125S	CP8025H	CP8035S	CM7115A	CM7125A	CM7215	CM7220	CK6105	CK6115	CH3005
	TNMG160404-KM	16.5	9.525	4.76	3.81	0.4												●	○
	TNMG160408-KM	16.5	9.525	4.76	3.81	0.8												●	○
	TNMG160412-KM	16.5	9.525	4.76	3.81	1.2												●	○
	TNMG220408-KM	22	12.7	4.76	5.16	0.8												●	○
	TNMG220412-KM	22	12.7	4.76	5.16	1.2												●	○
	TNMG220416-KM	22	12.7	4.76	5.16	1.6												●	○
	TNMG270412-KM	27	15.875	6.35	6.35	1.2												●	○
	TNMG270416-KM	27	15.875	6.35	6.35	1.6												●	○
	TNMG160404-CK	16.5	9.525	4.76	3.81	0.4												○	●
	TNMG160408-CK	16.5	9.525	4.76	3.81	0.8												○	●
	TNMG160412-CK	16.5	9.525	4.76	3.81	1.2												○	●
	TNMA160404	16.5	9.525	4.76	3.81	0.4												○	●
	TNMA160408	16.5	9.525	4.76	3.81	0.8												○	●
	TNMA160412	16.5	9.525	4.76	3.81	1.2												○	●
	TNMA220408	22	12.7	4.76	5.16	0.8												○	●
	TNMA220412	22	12.7	4.76	5.16	1.2												○	●
	TNMG160404-NH	16.5	9.525	4.76	3.81	0.4													●
	TNMG160408-MH	16.5	9.525	4.76	3.81	0.8													●

● Ready Stock ○ Available for Production

### Negative Turning Inserts

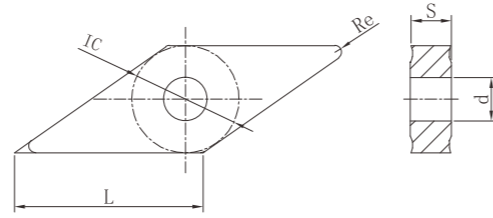

Shape	Type	Basic Dimension (mm)					P					M				K	H		
		L	IC	S	d	Re	CP8115	CP8115S	CP8125	CP8125S	CP8025H	CP8035S	CM7115A	CM7125A	CM7215	CM7220	CK6105	CK6115	CH3005
	VNMG160404-PM	16.6	9.525	4.76	3.81	0.4	○	○	○	●	○	○							
	VNMG160408-PM	16.6	9.525	4.76	3.81	0.8	○	○	○	●	○	○							
	VNMG160412-PM	16.6	9.525	4.76	3.81	1.2	○	○	○	●	○	○							
	VNMG160404-PF	16.6	9.525	4.76	3.81	0.4	○	●	○	○									
	VNMG160408-PF	16.6	9.525	4.76	3.81	0.8	○	●	○	○									
	VNMG160402-MM	16.6	9.525	4.76	3.81	0.2							●	○	●	○			
	VNMG160404-MM	16.6	9.525	4.76	3.81	0.4							●	○	●	○			
	VNMG160408-MM	16.6	9.525	4.76	3.81	0.8							●	○	●	○			
	VNMG160412-MM	16.6	9.525	4.76	3.81	1.2							●	○	●	○			
	VNMG160404-MQ	16.6	9.525	4.76	3.81	0.4							○	○	●	●			
	VNMG160408-MQ	16.6	9.525	4.76	3.81	0.8							○	○	●	●			
	VNMG160404-MF	16.6	9.525	4.76	3.81	0.4							○	○	●	●			
	VNMG160408-MF	16.6	9.525	4.76	3.81	0.8							○	○	●	●			
	VNMG160404-SM	16.6	9.525	4.76	3.81	0.4							●	○	●	○			
	VNMG160408-SM	16.6	9.525	4.76	3.81	0.8							●	○	●	○			
	VNMG160404-KM	16.6	9.525	4.76	3.81	0.4											●	○	
	VNMG160408-KM	16.6	9.525	4.76	3.81	0.8											●	○	
	VNMG160412-KM	16.6	9.525	4.76	3.81	1.2											●	○	
	VNMG160404-CK	16.6	9.525	4.76	3.81	0.4											○	●	
	VNMG160408-CK	16.6	9.525	4.76	3.81	0.8											○	●	
	VNMG160412-CK	16.6	9.525	4.76	3.81	1.2											○	●	
	VNMA160408	16.6	9.525	4.76	3.81	0.8											○	●	
	VNMA160412	16.6	9.525	4.76	3.81	1.2											○	●	
	VNMG160404-MH	16.6	9.525	4.76	3.81	0.4													●
	VNMG160408-MH	16.6	9.525	4.76	3.81	0.8													●

● Ready Stock ○ Available for Production

### Negative Turning Inserts

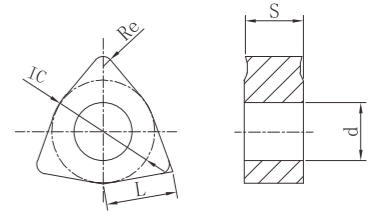

Shape	Type	Basic Dimension (mm)					P					M				K	H			
		L	IC	S	d	Re	CP8115	CP8115S	CP8125	CP8125S	CP8025H	CP8035S	CM7115A	CM7125A	CM7215	CM7220	CK6105	CK6115	CH3005	
	WNMG060408-PM	6.5	9.525	4.76	3.81	0.8	○	○	○	●	○									
	WNMG060412-PM	6.5	9.525	4.76	3.81	1.2	○	○	○	●	○									
	WNMG080404-PM	8.7	12.7	4.76	5.16	0.4	○	○	○	●	○									
	WNMG080408-PM	8.7	12.7	4.76	5.16	0.8	○	○	○	●	○									
	WNMG080412-PM	8.7	12.7	4.76	5.16	1.2	○	○	○	●	○									
	WNMG080416-PM	8.7	12.7	4.76	5.16	1.6	○	○	○	●	○									
	WNMG080404-PF	8.7	12.7	4.76	5.16	0.4	○	●	○	○										
	WNMG080408-PF	8.7	12.7	4.76	5.16	0.8	○	●	○	○										
	WNMG080416-PF	8.7	12.7	4.76	5.16	1.6	○	●	○	○										
	WNMG060404-MM	6.5	9.525	4.76	3.81	0.4							●	○	●	○				
	WNMG060408-MM	6.5	9.525	4.76	3.81	0.8							●	○	●	○				
	WNMG060412-MM	6.5	9.525	4.76	3.81	1.2							●	○	●	○				
	WNMG080404-MM	8.7	12.7	4.76	5.16	0.4							●	○	●	○				
	WNMG080408-MM	8.7	12.7	4.76	5.16	0.8							●	○	●	○				
	WNMG080412-MM	8.7	12.7	4.76	5.16	1.2							●	○	●	○				
	WNMG080404-MQ	8.7	12.7	4.76	5.16	0.4							○	○	●	●				
	WNMG080408-MQ	8.7	12.7	4.76	5.16	0.8							○	○	●	●				
	WNMG060404-MF	6.5	9.525	4.76	3.81	0.4							○	○	●	●				
	WNMG080404-MF	8.7	12.7	4.76	5.16	0.4							○	○	●	●				
	WNMG080408-MF	8.7	12.7	4.76	5.16	0.8							○	○	●	●				
	WNMG060404-SM	6.5	9.525	4.76	3.81	0.4							●	○	●	○				
	WNMG060408-SM	6.5	9.525	4.76	3.81	0.8							●	○	●	○				
	WNMG060412-SM	6.5	9.525	4.76	3.81	1.2							●	○	●	○				
	WNMG080404-SM	8.7	12.7	4.76	5.16	0.4							●	○	●	○				
	WNMG080408-SM	8.7	12.7	4.76	5.16	0.8							●	○	●	○				
	WNMG080412-SM	8.7	12.7	4.76	5.16	1.2							●	○	●	○				
	WNMG080404-KM	8.7	12.7	4.76	5.16	0.4													●	○
	WNMG080408-KM	8.7	12.7	4.76	5.16	0.8													●	○
	WNMG080412-KM	8.7	12.7	4.76	5.16	1.2													●	○

● Ready Stock ○ Available for Production

### Negative Turning Inserts

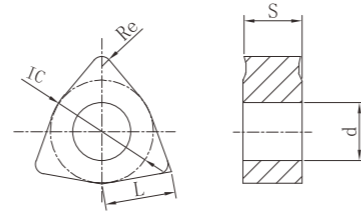

Shape	Type	Basic Dimension (mm)					P			M		K	H								
		L	IC	S	d	Re	CP8115	CP8115S	CP8125	CP8125S	CP8025H	CP8035S	CM7115A	CM7125A	CM7215	CM7220	CK6105	CK6115	CH3005		
	WNMG080404-CK	8.7	12.7	4.76	5.16	0.4														○ ●	
	WNMG080408-CK	8.7	12.7	4.76	5.16	0.8														○ ●	
	WNMA080404	8.7	12.7	4.76	5.16	0.4														○ ●	
	WNMA080408	8.7	12.7	4.76	5.16	0.8														○ ●	
	WNMG0800404-MH	8.7	12.7	4.76	5.16	0.4															●
	WNMG080408-MH	8.7	12.7	4.76	5.16	0.8															●

● Ready Stock ○ Available for Production



### Positive turning inserts

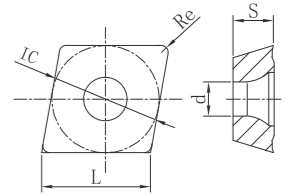

Shape	Type	Basic Dimension (mm)					P			M		K	H								
		L	IC	S	d	Re	CP8115	CP8115S	CP8125	CP8125S	CP8025H	CP8035S	CM7115A	CM7125A	CM7215	CM7220	CK6105	CK6115	CH3005		
	CCMT060204-HF	6.4	6.35	2.38	2.8	0.4	○	○	○	●											
	CCMT060208-HF	6.4	6.35	2.38	2.8	0.8	○	○	○	●											
	CCMT09T304-HF	9.7	9.525	3.97	4.4	0.4	○	○	○	●											
	CCMT09T308-HF	9.7	9.525	3.97	4.4	0.8	○	○	○	●											
	CCMT060204-PM	6.4	6.35	2.38	2.8	0.4	○	○	○	●											
	CCMT060208-PM	6.4	6.35	2.38	2.8	0.8	○	○	○	●											
	CCMT09T304-PM	9.7	9.525	3.97	4.4	0.4	○	○	○	●											
	CCMT09T308-PM	9.7	9.525	3.97	4.4	0.8	○	○	○	●											
	CCMT120404-PM	12.9	12.7	4.76	5.16	0.4	○	○	○	●											
	CCMT120408-PM	12.9	12.7	4.76	5.16	0.8	○	○	○	●											
	CCMT060204-PF	6.4	6.35	2.38	2.8	0.4	○	○	○	●											
	CCMT060208-PF	6.4	6.35	2.38	2.8	0.8	○	○	○	●											
	CCMT09T304-PF	9.7	9.525	3.97	4.4	0.4	○	○	○	●											
	CCMT09T308-PF	9.7	9.525	3.97	4.4	0.8	○	○	○	●											
	CCMT120404-PF	12.9	12.7	4.76	5.16	0.4	○	○	○	●											
	CCMT120408-PF	12.9	12.7	4.76	5.16	0.8	○	○	○	●											
	CCMT060202-MM	6.4	6.35	2.38	2.8	0.2						●	○	●	○						
	CCMT060204-MM	6.4	6.35	2.38	2.8	0.4						●	○	●	○						
	CCMT060208-MM	6.4	6.35	2.38	2.8	0.8						●	○	●	○						
	CCMT09T304-MM	9.7	9.525	3.97	4.4	0.4						●	○	●	○						
	CCMT09T308-MM	9.7	9.525	3.97	4.4	0.8						●	○	●	○						
	CCMT120404-MM	12.9	12.7	4.76	5.16	0.4						●	○	●	○						
	CCMT120408-MM	12.9	12.7	4.76	5.16	0.8						●	○	●	○						
	CCMT120412-MM	12.9	12.7	4.76	5.16	1.2						●	○	●	○						
	CCMT060204-KM	6.4	6.35	2.38	2.8	0.4														○ ●	
	CCMT060208-KM	6.4	6.35	2.38	2.8	0.8														○ ●	
	CCMT09T304-KM	9.7	9.525	3.97	4.4	0.4														○ ●	
	CCMT09T308-KM	9.7	9.525	3.97	4.4	0.8														○ ●	
	CCMT120404-KM	12.9	12.7	4.76	5.16	0.4														○ ●	
	CCMT120408-KM	12.9	12.7	4.76	5.16	0.8														○ ●	
	CCMT120412-KM	12.9	12.7	4.76	5.16	1.2														○ ●	
	CCGT060204-MH	6.4	6.35	2.38	2.8	0.4															●
	CCGT060208-MH	6.4	6.35	2.38	2.8	0.8															●
	CCGT09T304-MH	6.4	6.35	3.97	3.81	0.4															●
	CCGT09T308-MH	6.4	6.35	3.97	3.81	0.8															●

● Ready Stock ○ Available for Production

### Positive turning inserts

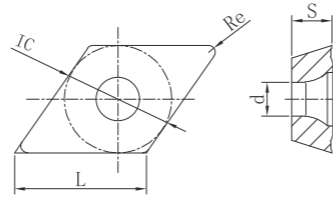

Shape	Type	Basic Dimension (mm)					P					M				K	H		
		L	IC	S	d	Re	CP8115	CP8115S	CP8125	CP8125S	CP8025H	CP8035S	CM7115A	CM7125A	CM7215	CM7220	CK6105	CK6115	CH3005
	DCMT070204-HF	7.8	6.35	2.38	2.8	0.4	○	○	○	●	○								
	DCMT070208-HF	7.8	6.35	2.38	2.8	0.8	○	○	○	●	○								
	DCMT11T304-HF	11.6	9.525	3.97	4.4	0.4	○	○	○	●	○								
	DCMT11T308-HF	11.6	9.525	3.97	4.4	0.8	○	○	○	●	○								
	DCMT070204-PM	7.8	6.35	2.38	2.8	0.4	○	○	○	●	○								
	DCMT070208-PM	7.8	6.35	2.38	2.8	0.8	○	○	○	●	○								
	DCMT11T304-PM	11.6	9.525	3.97	4.4	0.4	○	○	○	●	○								
	DCMT11T308-PM	11.6	9.525	3.97	4.4	0.8	○	○	○	●	○								
	DCMT11T304-PF	11.6	9.525	3.97	4.4	0.4	○	○	○	●	○								
	DCMT11T308-PF	11.6	9.525	3.97	4.4	0.8	○	○	○	●	○								
	DCMT070204-MM	7.8	6.35	2.38	2.8	0.4						○	●	○	●				
	DCMT070208-MM	7.8	6.35	2.38	2.8	0.8						○	●	○	●				
	DCMT11T304-MM	11.6	9.525	3.97	4.4	0.4						○	●	○	●				
	DCMT11T308-MM	11.6	9.525	3.97	4.4	0.8						○	●	○	●				
	DCMT070204-KM	7.8	6.35	2.38	2.8	0.4										○	●		
	DCMT070208-KM	7.8	6.35	2.38	2.8	0.8										○	●		
	DCMT11T304-KM	11.6	9.525	3.97	4.4	0.4										○	●		
	DCMT11T308-KM	11.6	9.525	3.97	4.4	0.8										○	●		
	DCGT11T304-MH	11.6	9.525	3.97	4.4	0.4													●
	DCGT11T308-MH	11.6	9.525	3.97	4.4	0.8													●

● Ready Stock ○ Available for Production

### Positive turning inserts

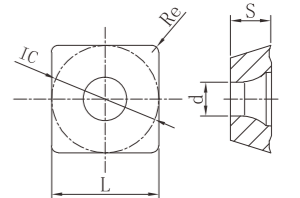

Shape	Type	Basic Dimension (mm)					P					M				K	H		
		L	IC	S	d	Re	CP8115	CP8115S	CP8125	CP8125S	CP8025H	CP8035S	CM7115A	CM7125A	CM7215	CM7220	CK6105	CK6115	CH3005
	SCMT09T304-HF	9.525	9.525	3.97	4.4	0.4	○	○	○	●	○								
	SCMT09T308-HF	9.525	9.525	3.97	4.4	0.8	○	○	○	●	○								
	SCMT120404-HF	12.7	12.7	4.76	5.56	0.4	○	○	○	●	○								
	SCMT120408-HF	12.7	12.7	4.76	5.56	0.8	○	○	○	●	○								
	SCMT120412-HF	12.7	12.7	4.76	5.56	1.2	○	○	○	●	○								
	SCMT09T304-PM	9.525	9.525	3.97	4.4	0.4	○	○	○	●	○								
	SCMT09T308-PM	9.525	9.525	3.97	4.4	0.8	○	○	○	●	○								
	SCMT120404-PM	12.7	12.7	4.76	5.56	0.4	○	○	○	●	○								
	SCMT120408-PM	12.7	12.7	4.76	5.56	0.8	○	○	○	●	○								
	SCMT120412-PM	12.7	12.7	4.76	5.56	1.2	○	○	○	●	○								
	SCMT09T304-PF	9.525	9.525	3.97	4.4	0.4	○	○	○	●	○								
	SCMT09T308-PF	9.525	9.525	3.97	4.4	0.8	○	○	○	●	○								
	SCMT120404-PF	12.7	12.7	4.76	5.56	0.4	○	○	○	●	○								
	SCMT120412-PF	12.7	12.7	4.76	5.56	1.2	○	○	○	●	○								
	SCMT09T304-MM	9.525	9.525	3.97	4.4	0.4						●	○	●	○				
	SCMT09T308-MM	9.525	9.525	3.97	4.4	0.8						●	○	●	○				
	SCMT120404-MM	12.7	12.7	4.76	5.56	0.4						●	○	●	○				
	SCMT120408-MM	12.7	12.7	4.76	5.56	0.8						●	○	●	○				
	SCMT120412-MM	12.7	12.7	4.76	5.56	1.2						●	○	●	○				
	SCMT09T304-KM	9.525	9.525	3.97	4.4	0.4											○	●	
	SCMT09T308-KM	9.525	9.525	3.97	4.4	0.8											○	●	
	SCMT120404-KM	12.7	12.7	4.76	5.56	0.4											○	●	
	SCMT120408-KM	12.7	12.7	4.76	5.56	0.8											○	●	
	SCMT120412-KM	12.7	12.7	4.76	5.56	1.2											○	●	

● Ready Stock ○ Available for Production

### Positive turning inserts

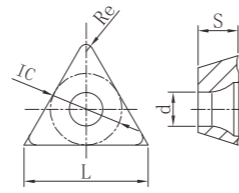

Shape	Type	Basic Dimension (mm)					P					M				K	H		
		L	IC	S	d	Re	CP8115	CP8115S	CP8125	CP8125S	CP8025H	CP8035S	CM7115A	CM7125A	CM7215	CM7220	CK6105	CK6115	CH3005
	TCMT110204-HF	11	6.35	2.38	2.8	0.4	○	○	○	●									
	TCMT110208-HF	11	6.35	2.38	2.8	0.8	○	○	○	●									
	TCMT16T304-HF	16.5	9.525	3.97	4.4	0.4	○	○	○	●									
	TCMT16T308-HF	16.5	9.525	3.97	4.4	0.8	○	○	○	●									
	TCMT090204-PM	9.6	5.56	2.38	2.5	0.4	○	○	○	●									
	TCMT090208-PM	9.6	5.56	2.38	2.5	0.8	○	○	○	●									
	TCMT110204-PM	11	6.35	2.38	2.8	0.4	○	○	○	●									
	TCMT110208-PM	11	6.35	2.38	2.8	0.8	○	○	○	●									
	TCMT160404-PM	16.5	9.525	3.97	4.4	0.4	○	○	○	●									
	TCMT160408-PM	16.5	9.525	3.97	4.4	0.8	○	○	○	●									
	TCMT110202-PF	11	6.35	2.38	2.8	0.2	○	○	○	●									
	TCMT110204-PF	11	6.35	2.38	2.8	0.4	○	○	○	●									
	TCMT110208-PF	11	6.35	2.38	2.8	0.8	○	○	○	●									
	TCMT16T304-PF	16.5	9.525	3.97	4.4	0.4	○	○	○	●									
	TCMT16T308-PF	16.5	9.525	3.97	4.4	0.8	○	○	○	●									
	TCMT090204-MM	9.6	5.56	2.38	2.5	0.4					●	○	●	○					
	TCMT110204-MM	11	6.35	2.38	2.8	0.4					●	○	●	○					
	TCMT110208-MM	11	6.35	2.38	2.8	0.8					●	○	●	○					
	TCMT16T304-MM	16.5	9.525	3.97	4.4	0.4					●	○	●	○					
	TCMT16T308-MM	16.5	9.525	3.97	4.4	0.8					●	○	●	○					
	TCMT110204-KM	11	6.35	2.38	2.8	0.4											○	●	
	TCMT110208-KM	11	6.35	2.38	2.8	0.8											○	●	
	TCMT16T304-KM	16.5	9.525	3.97	4.4	0.4											○	●	
	TCMT16T308-KM	16.5	9.525	3.97	4.4	0.8											○	●	
	TCGT110204-MH	11	6.35	2.38	2.8	0.4													●
	TCGT110208-MH	11	6.35	2.38	2.8	0.8													●

● Ready Stock ○ Available for Production

### Positive turning inserts

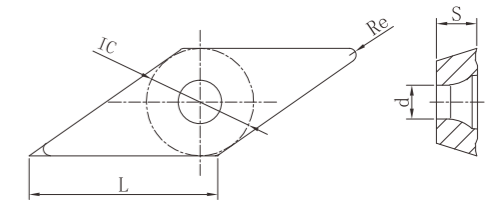

Shape	Type	Basic Dimension (mm)					P					M				K	H			
		L	IC	S	d	Re	CP8115	CP8115S	CP8125	CP8125S	CP8025H	CP8035S	CM7115A	CM7125A	CM7215	CM7220	CK6105	CK6115	CH3005	
	VBMT160404-HF	16.5	9.525	4.76	4.4	0.4	○	○	○	●										
	VBMT160408-HF	16.5	9.525	4.76	4.4	0.8	○	○	○	●										
	VBMT160404-PM	16.5	9.525	4.76	4.4	0.4	○	○	○	●										
	VBMT160408-PM	16.5	9.525	4.76	4.4	0.8	○	○	○	●										
	VBMT160412-PM	16.5	9.525	4.76	4.4	1.2	○	○	○	●										
	VBMT160404-PF	16.5	9.525	4.76	4.4	0.4	○	○	○	●										
	VBMT160408-PF	16.5	9.525	4.76	4.4	0.8	○	○	○	●										
	VBMT160404-MM	16.5	9.525	4.76	4.4	0.4									●	○	●	○		
	VBMT160408-MM	16.5	9.525	4.76	4.4	0.8									●	○	●	○		
	VBMT160412-MM	16.5	9.525	4.76	4.4	1.2									●	○	●	○		
	VCMT110304-MM	11	6.35	3.18	2.8	0.4									●	○	●	○		
	VCMT110308-MM	11	6.35	3.18	2.8	0.8									●	○	●	○		
	VBMT160404-KM	16.5	9.525	4.76	4.4	0.4													○	●
	VBMT160408-KM	16.5	9.525	4.76	4.4	0.8													○	●
	VBMT160412-KM	16.5	9.525	4.76	4.4	1.2													○	●
	VCMT110304-KM	11	6.35	3.18	2.8	0.4													○	●
	VCMT110308-KM	11	6.35	3.18	2.8	0.8													○	●

● Ready Stock ○ Available for Production

## Milling Inserts

- ▶ Milling Insert Code System (ISO)
- ▶ Milling Inserts



# B

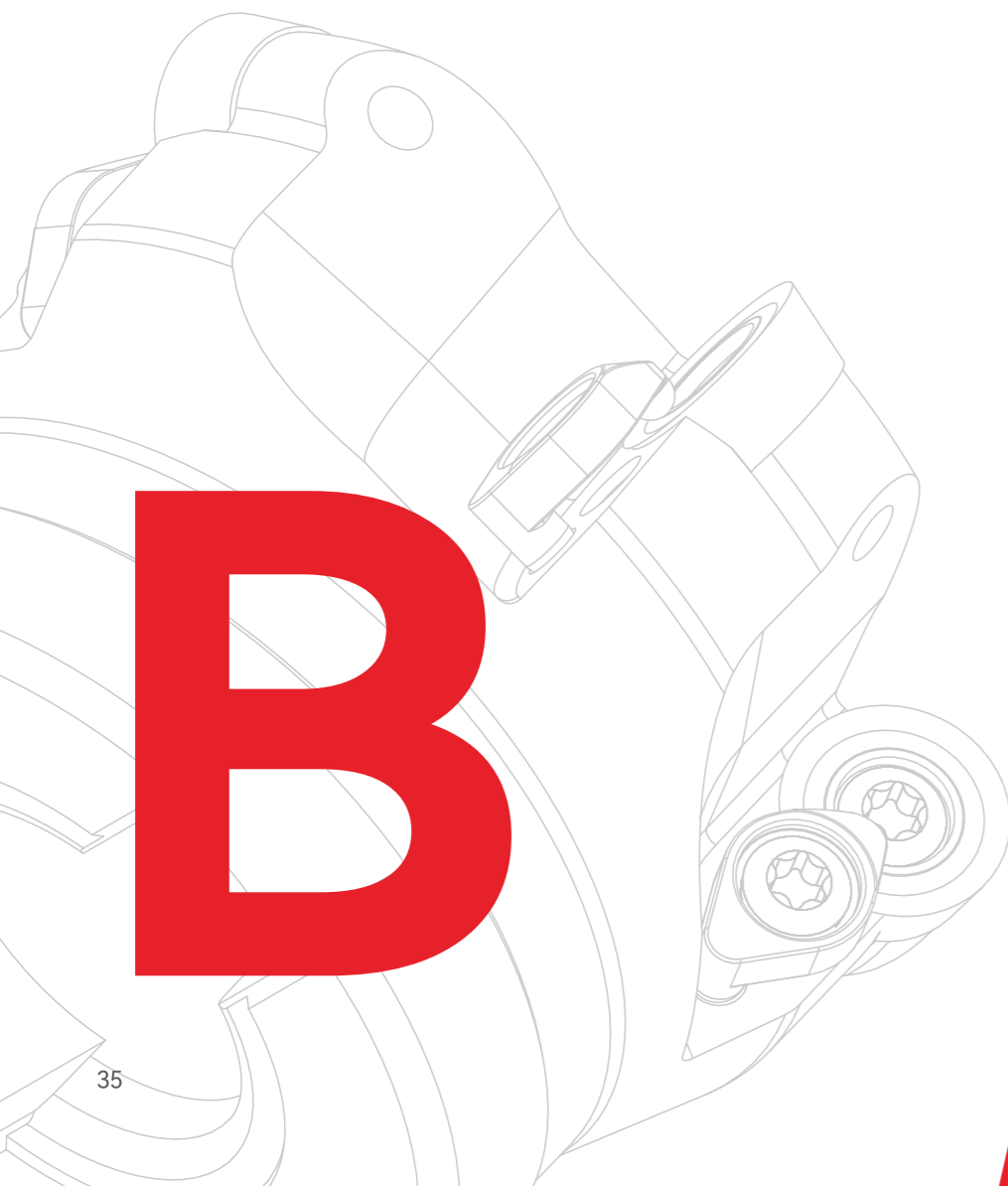

### Milling Insert Code System (ISO)

Code	Relief Angle	Code	Hole	Chipbreaker	Section Sketch	Code	Hole	Chipbreaker	Section Sketch
<b>A</b>	3°	<b>B</b>	Y	N		<b>N</b>	N	N	
<b>B</b>	5°	<b>H</b>	Y	Single Side		<b>R</b>	N	Single Side	
<b>C</b>	7°	<b>C</b>	Y	N		<b>F</b>	N	Double Side	
<b>D</b>	15°	<b>J</b>	Y	Double Side		<b>A</b>	Y	N	
<b>E</b>	20°	<b>W</b>	Y	N		<b>M</b>	Y	Single Side	
<b>F</b>	25°	<b>T</b>	Y	Single Side		<b>G</b>	Y	Double Side	
<b>G</b>	30°	<b>Q</b>	Y	N		<b>X</b>	---	---	Special
<b>N</b>	0°	<b>U</b>	Y	Double Side					
<b>P</b>	11°								
<b>O</b>	Others								

Inscribed Circle Diameter (mm)	Inserts Shape							
	C	D	R	S	T	V	W	K
3.97					6			
5.5			5					
5.56					9			
6			6					
6.35	6	7			11	11		
8			8					
9.525	9	11	9	9	16	16	6	16
10			10					
12			12					
12.7	12	15	12	12	22	22	8	
15.875	16		15	15	27			
16		19	16					
19.05	19		19	19	33			
20		25	20					
25	25		25					
25.4			25	25	25			
31.75			31	32	32			
32			32					

Code	Thickness (mm)
<b>0</b>	0.79
<b>T0</b>	0.99
<b>01</b>	1.59
<b>T1</b>	1.98
<b>02</b>	2.38
<b>T2</b>	2.78
<b>03</b>	3.18
<b>T3</b>	3.97
<b>04</b>	4.76
<b>T4</b>	4.96
<b>05</b>	5.56
<b>T5</b>	5.95
<b>06</b>	6.35
<b>T6</b>	6.75
<b>07</b>	7.94
<b>09</b>	9.52
<b>T9</b>	9.72
<b>10</b>	11.11
<b>12</b>	12.70

Code	Relief Angle	Code	Relief Angle
<b>A</b>	45°	<b>A</b>	3°
<b>D</b>	60°	<b>B</b>	5°
<b>E</b>	75°	<b>C</b>	7°
<b>F</b>	85°	<b>D</b>	15°
<b>P</b>	90°	<b>E</b>	20°
<b>Z</b>	Others	<b>F</b>	25°
		<b>G</b>	30°
		<b>N</b>	0°
		<b>P</b>	11°
		<b>Z</b>	Others

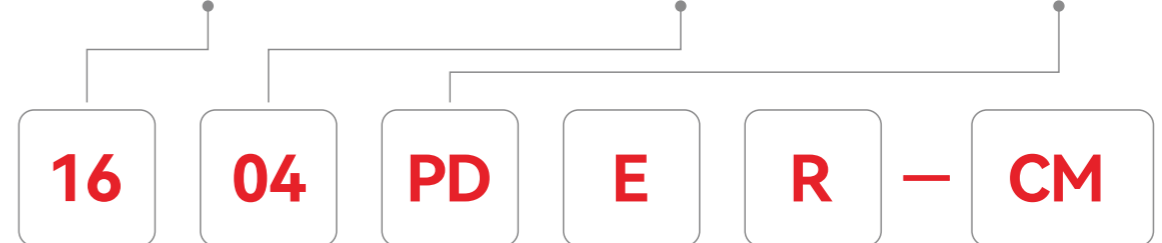
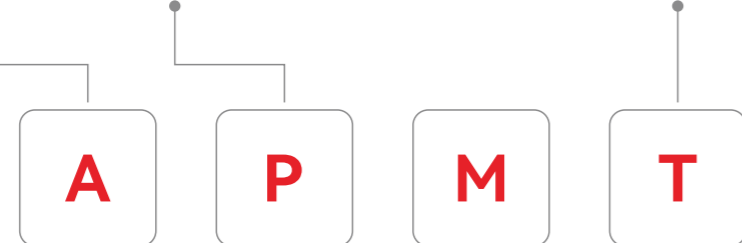

Tolerance										
Code	Cutting Point Height (mm)	Inscribed Circle ΦTol.	Thickness Tol.(mm)	• Cutting Point Height (mm) Tolerance						
				Inscribed Circle	Equilateral Triangle	Square	80° Rhomb	55° Rhomb	35° Rhomb	Round
<b>A</b>	±0.005	±0.025	±0.025	6.35	±0.08	±0.08	±0.08	±0.11	±0.16	---
<b>F</b>	±0.005	±0.013	±0.025	9.525	±0.08	±0.08	±0.08	±0.11	±0.16	---
<b>C</b>	±0.013	±0.025	±0.025	12.7	±0.13	±0.13	±0.13	±0.15	---	---
<b>H</b>	±0.013	±0.013	±0.025	15.875	±0.15	±0.15	±0.15	±0.18	---	---
<b>E</b>	±0.025	±0.025	±0.025	19.05	±0.15	±0.15	±0.15	±0.18	---	---
<b>G</b>	±0.025	±0.025	±0.13	25.4	---	±0.18	---	---	---	---
<b>J</b>	±0.005	±0.05~±0.13	±0.025							
<b>K</b>	±0.013	±0.05~±0.13	±0.025							
<b>L</b>	±0.025	±0.05~±0.13	±0.025							
<b>M</b>	±0.08~±0.18	±0.05~±0.13	±0.13							
<b>N</b>	±0.08~±0.18	±0.05~±0.13	±0.025							
<b>U</b>	±0.13~±0.38	±0.08~±0.25	±0.13							

Chamfering of Cutting Edge										
F	E	T	S							
			0	1	2	3	4	5		
			5°	10°	15°	20°	25°	30°		
			0	1	2	3	4	5	6	7
			0.1	0.15	0.2	0.25	0.3	0.35	0.4	0.45

Cutting Direction	
Code	Direction
<b>R</b>	Right
<b>L</b>	Left
<b>N</b>	Neutral

Chipbreaker Code	
Code	Code
<b>CR</b>	<b>CM</b>

### Milling Inserts

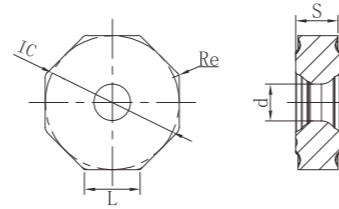

Shape	Type	Basic Dimension (mm)					P		M	K	H	
		L	W	S	d	Re	CA5120	CA5120H	CA5110	CK6020	CA5105	CH5005
	ONGU050403-CR	5.26	12.7	4.76	4.4	0.3	●	○	●	○	●	
	ONMU060408-CR	6.58	15.875	4.9	4.35	0.8	●	○	●	○	●	
	ONGU080508-CR	8.36	20.2	5.8	5.4	0.8	●	○	●	○	●	
	ODMT050408-CR	5.26	12.7	4.76	4.4	0.8	●	○	●	○	●	
	ODMT0605ANN-CR	6.58	15.875	5.56	5.5	0.8	●	○	●	○	●	

● Ready Stock ○ Available for Production

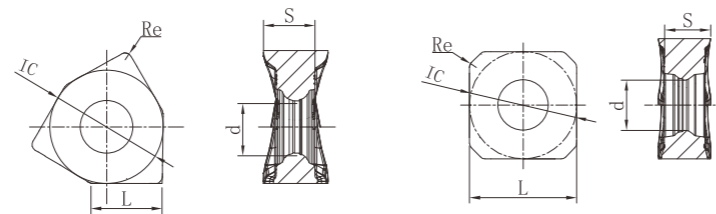

Shape	Type	Basic Dimension (mm)					P		M	K	H	
		L	W	S	d	Re	CA5120	CA5120H	CA5110	CK6020	CA5105	CH5005
	WNMU060408R-YM	6.41	10.15	4.36	4.2	0.8	●	○	●	○	●	
	WNMU040304EN-YM	4.22	6.7	3.06	3.2	0.4	●	○	●	○	●	
	SNMU1206ANN-Y	12	12.7	5.5	5.95	0.8	●	○	●	○	●	
	SNMU120612-Y	12	12.7	5.56	6	1.2	●	○	●	○	●	

● Ready Stock ○ Available for Production

### Milling Inserts

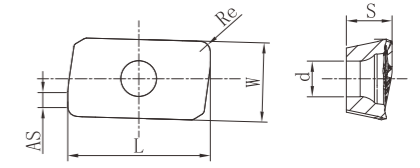

Shape	Type	Basic Dimension (mm)					P		M	K	H	
		L	W	S	d	Re	CA5120	CA5120H	CA5110	CK6020	CA5105	CH5005
	APMT1135PDER-CM	11.25	6.26	3.5	2.8	0.8	●	●	●	●	●	●
	APMT1604PDER-CM	17.44	9.32	5.2	4.4	0.8	●	●	●	●	●	●

● Ready Stock ○ Available for Production

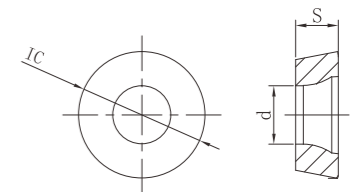

Shape	Type	Basic Dimension (mm)			P		M	K	H	
		IC	S	d	CA5120	CA5120H	CA5110	CK6020	CA5105	CH5005
	RPMT1003MO-CM	10	3.18	4.6	●	○	●	○	●	●
	RPMT1204MO-CM	12	4.76	4.4	●	○	●	○	●	●
	RPMT10T3-MR	10	3.97	4	●	○	●	○	●	●
	RPMT1204MO-MR	12	4.76	4.45	●	○	●	○	●	●
	RPMT1604MO-MR	16	4.76	5.6	●	○	●	○	●	●
	RPMW08T2MO	8	2.78	3.06	●	○	○	○	●	●
	RPMW1003MO	10	3.18	4.6	●	○	○	○	●	●
	RPGW1003MOEN	10	3.18	4.6	●	○	○	○	●	●
	RDMW10T3MOTN	10	3.97	4.4	●	○	○	○	●	●

● Ready Stock ○ Available for Production

# Drilling Inserts

## ▶ Standard Drilling Inserts

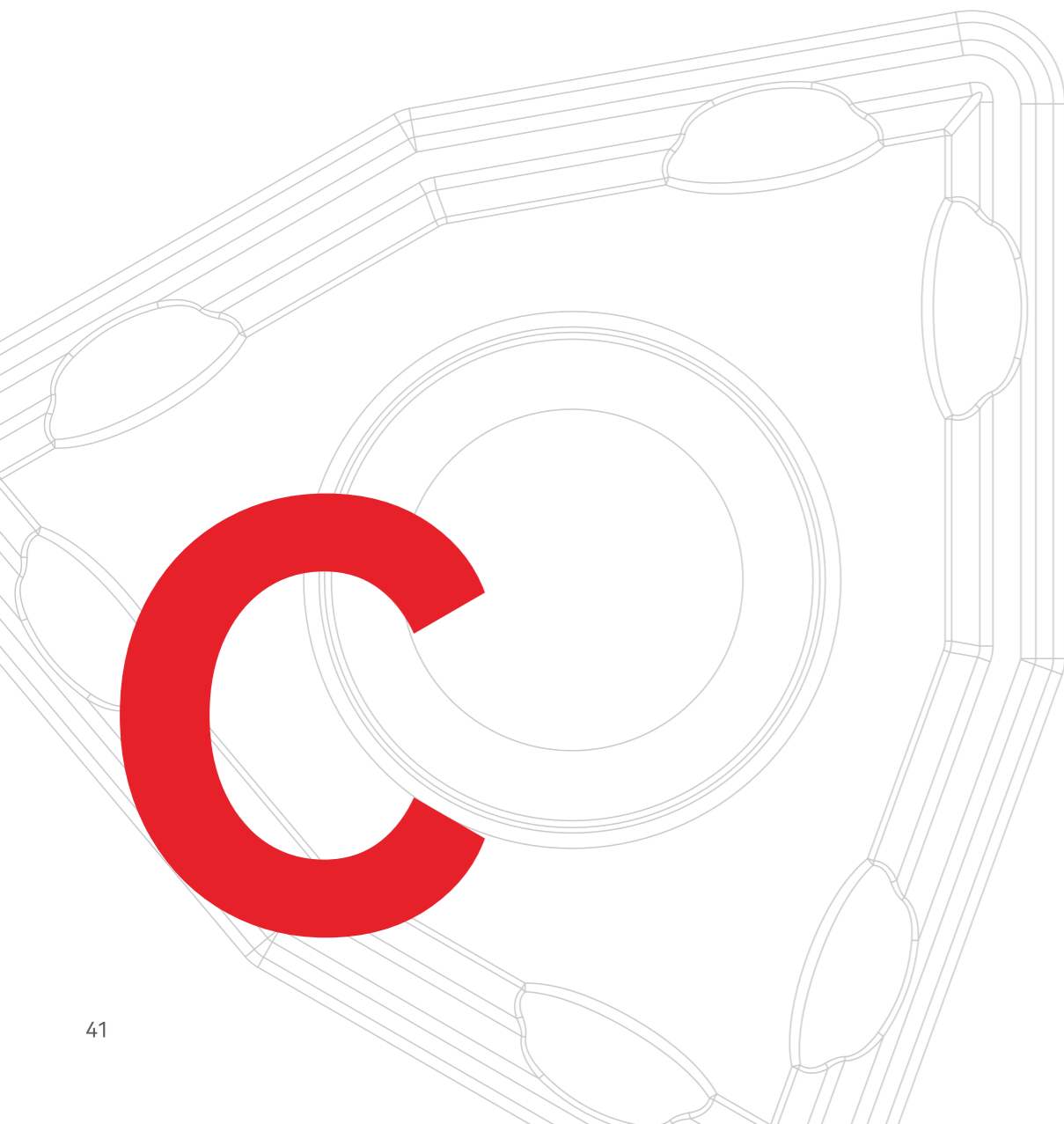

## Standard Drilling Inserts

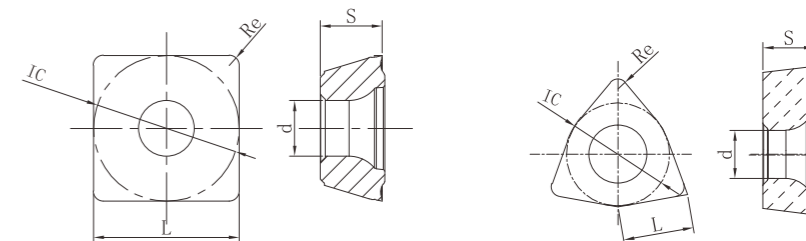

Shape	Type	Basic Dimension (mm)					P		M		K	H
		L	IC	S	d	Re	CA5120	CA5120H	CM7115A	CM7125A	CA5105	CA5105
	SPMG050204-DG	5	5	2.38	2.2	0.4	●	●	○	●		●
	SPMG060204-DG	6	6	2.38	2.6	0.4	●	●	○	●		●
	SPMG07T308-DG	7.94	7.94	3.97	2.8	0.8	●	●	○	●		●
	SPMG090408-DG	9.8	9.8	4.3	4.2	0.8	●	●	○	●		●
	SPMG110408-DG	11.5	11.5	4.76	4.4	0.8	●	●	○	●		●
	SPMG140512-DG	14.3	14.3	5.2	5.75	1.2	●	●	○	●		●
	WCMX030208-U	3	5.56	2.38	2.8	0.8	●	●	○	●		●
	WCMX040208-U	4	6.35	2.38	3.1	0.8	●	●	○	●		●
	WCMX050308-U	5	7.94	3.18	3.2	0.8	●	●	○	●		●
	WCMX06T308-U	6	9.525	3.97	3.7	0.8	●	●	○	●		●
	WCMX080412-U	8	12.7	4.76	4.4	1.2	●	●	○	●		●

● Ready Stock    ○ Available for Production

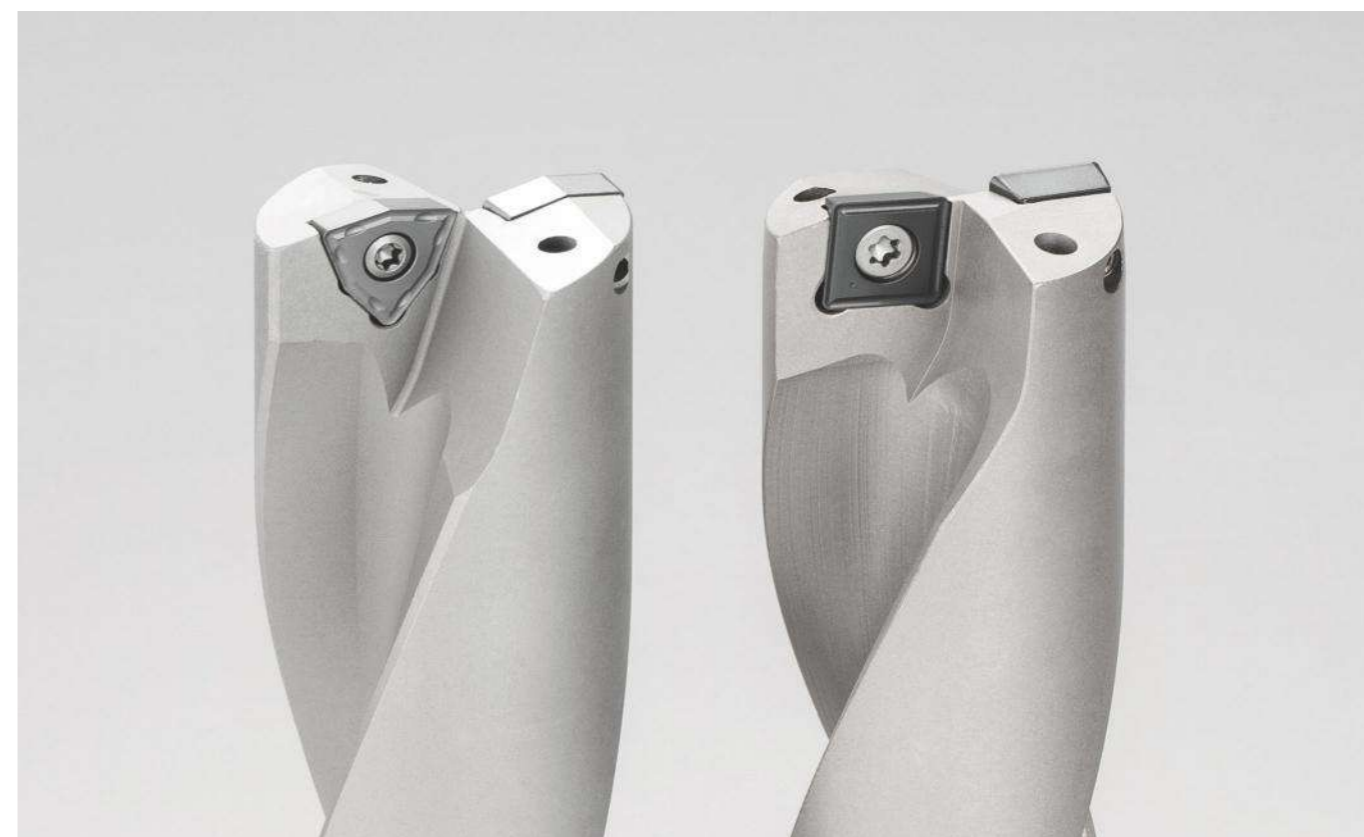

## Grooving Inserts

### ▶ Parting & Grooving Inserts

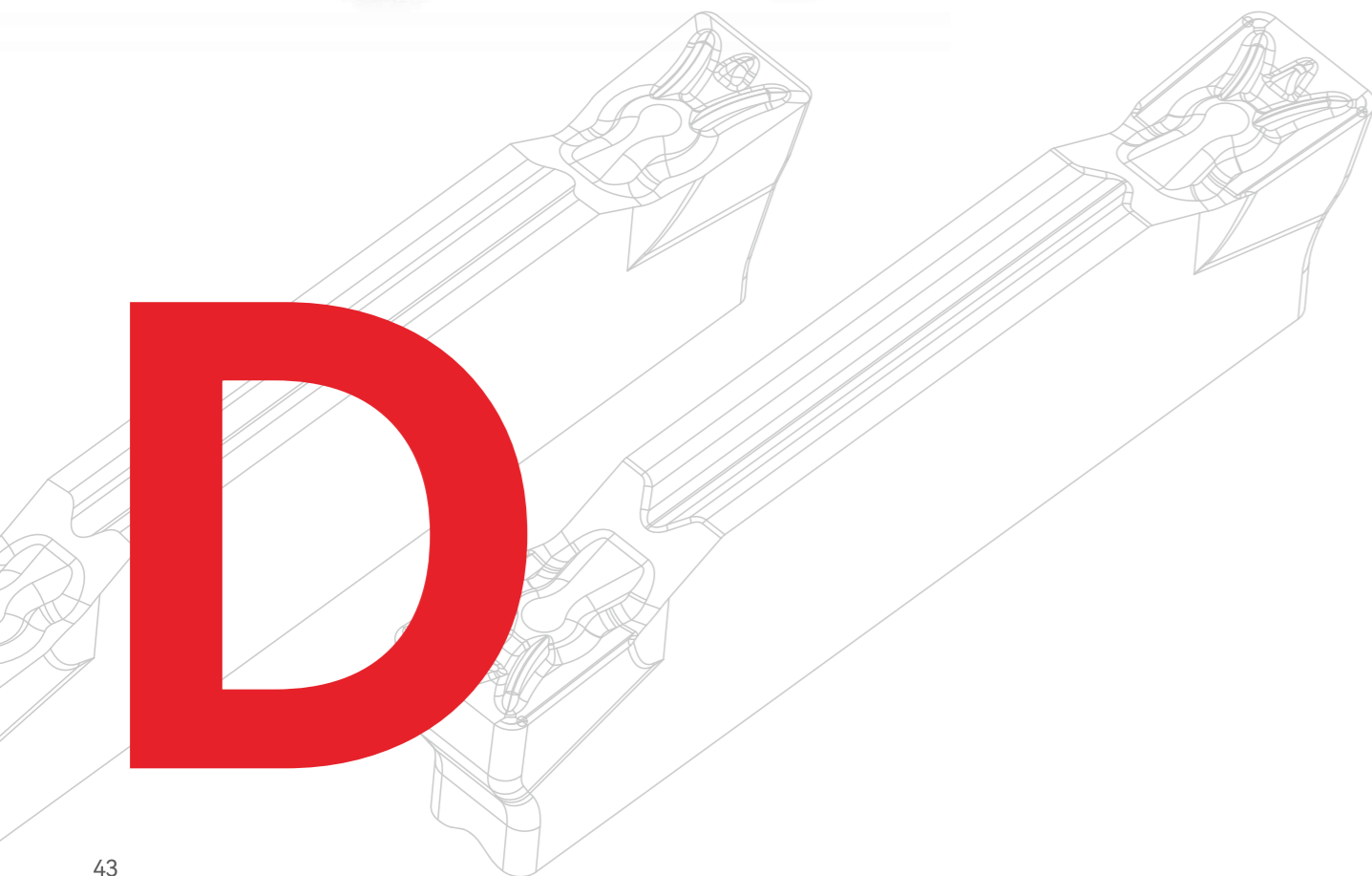

## Parting & Grooving Inserts

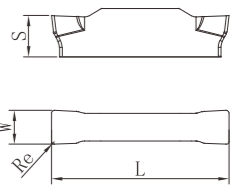

Shape	Type	Basic Dimension (mm)				P			M		K
		L	W	S	Re	CA5120	CA5120H	CM7115A	CM7125A	CA5105	CA5105
	MGMN200-GM	16	2	3.55	0.2	●	○	○	○	●	○
	MGMN250-GM	18.5	2.5	3.57	0.2	●	○	○	○	●	○
	MGMN300-GM	21	3	4.83	0.4	●	○	○	○	●	○
	MGMN400-GM	21	4	4.88	0.3	●	○	○	○	●	○
	MGMN500-GM	26	5	5.8	0.4	●	○	○	○	●	○

● Ready Stock    ○ Available for Production



## Threading Inserts

- ▶ Threading Insert Code System (ISO)
- ▶ ISO Metric Thread, 60° Thread Profile
- ▶ General-Purpose Thread
- ▶ UN (Unified National) Thread
- ▶ Whitworth Thread
- ▶ American Standard Pipe Thread
- ▶ British Standard Pipe Thread

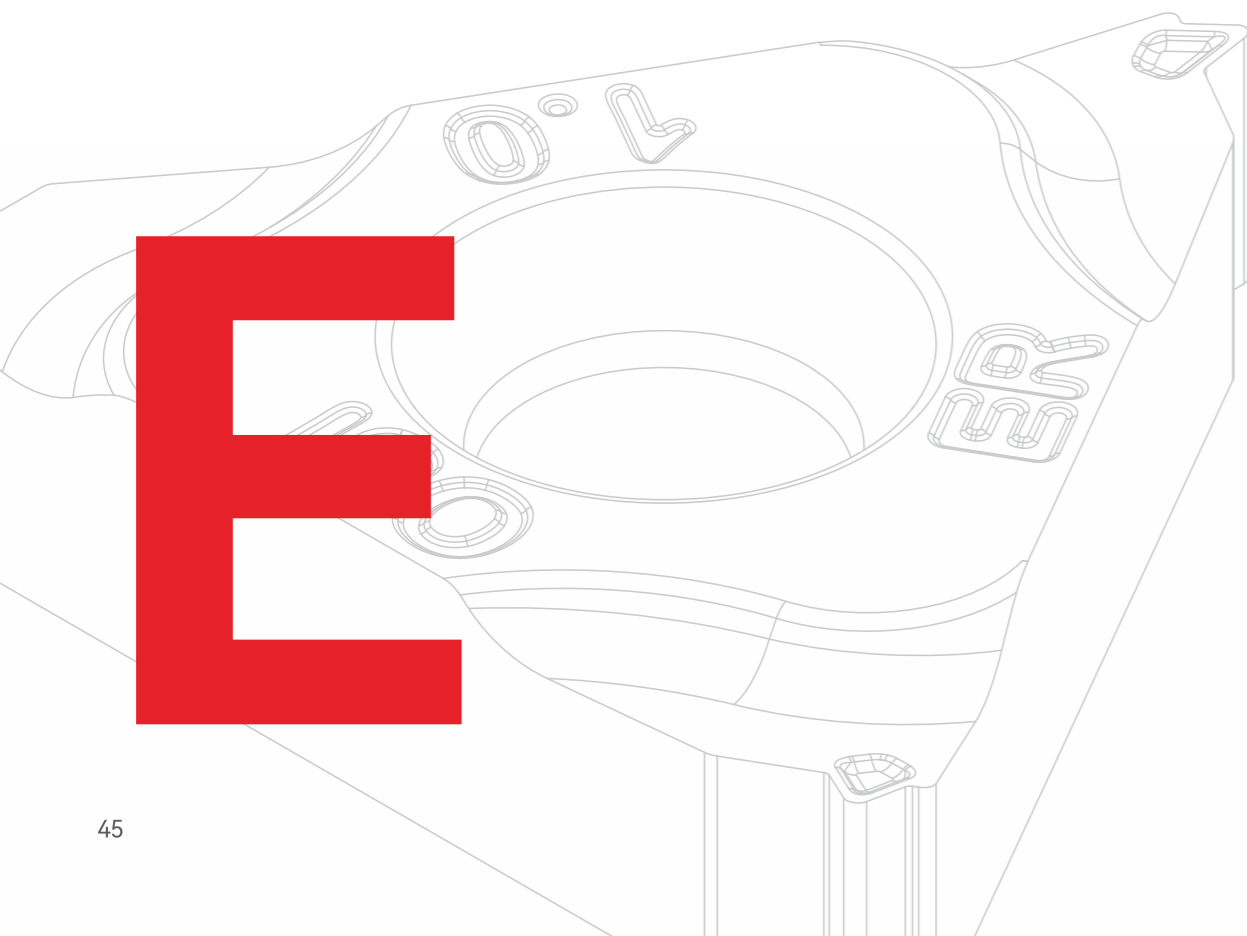

## Threading Inserts Chipbreaker

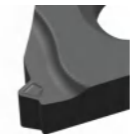
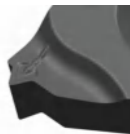
External Thread	Internal Thread
<p><b>Arc-shaped Curved Surface</b> Excellent chip control capability, effectively curling and evacuating chips.</p> <p><b>Concave Design</b> Integrated chip-reducing groove design lowers cutting resistance and enhances heat dissipation.</p> <p><b>Precision Thread Profile Angle</b> Accurately engineered thread profile angle ensures tighter and more precise thread engagement.</p> 	<p><b>Arc-Shaped Curved Surface</b> Provides excellent chip control, effectively curling and evacuating chips.</p> <p><b>Concave Design</b> Integrated chip-reducing groove minimizes cutting resistance and improves heat dissipation.</p> <p><b>Efficient Chip Breaking in Internal Threading</b> Ensures reliable chip control during internal threading operations.</p> <p><b>Precision Thread Profile Angle</b> Precisely engineered thread profile angle ensures tighter and more accurate thread engagement.</p> 

## Threading Insert Code System (ISO)

Code	IC(mm)
8	5
11	6.35
16	9.525
22	12.7
27	15.875

E-External thread
I-Internal thread
□-External&internal thread

R-Right hand insert
L-Left hand insert
□-Neutral insert

**Insert Type**      **Insert Type**      **Insert Hand**

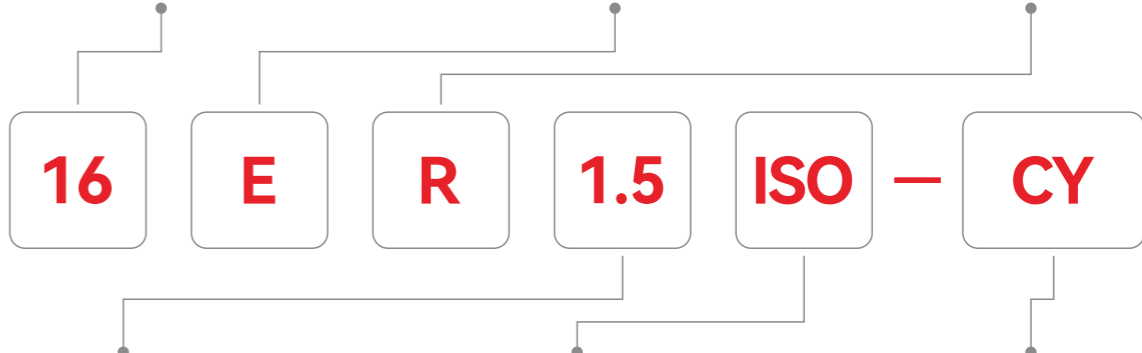

Pitch/Threads Per Inch		
Full Profile		
Pitch(mm)	TPI	
0.35-5.0	72-5	
Partical Profile		
Code	Pitch(mm)	TPI
A	0.5-1.5	48-16
AG	0.5-3.0	48-8
G	1.75-3.0	14-8
N	3.5-5.0	7-5

Thread Standard	
60°	60°-Generalpurpose threading
55°	55°-General purpose threading
ISO	ISO metric thread
UN	Unified National thread
W	British Standard Whitworth Thread
NPT	National Pipe Taper
BSPT	British Standard Pipe Taper
ACME	ACME thread
STACME	Stub ACME thread
ABUT	Buttress thread
API	API thread
UNJ	Unified thread (controlled root radius)

Special Information
Used to define special thread forms, tolerances, or other custom requirements

### ISO Metric Thread, 60° Thread Profile

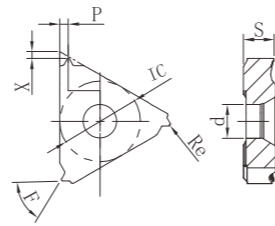

#### EXTERNAL THREAD

Shape	Type	Pitch/Threads Per Inch	Basic Dimension (mm)							PVD Grade	
			IC	P	X	Re	S	d	F	CM7125A	CM7215
	16ER1.0ISO-CY	1.0	9.525	0.7	0.8	0.15	3.5	4.0	60°	●	○
	16ER1.25ISO-CY	1.25	9.525	0.9	0.8	0.18	3.5	4.0	60°	●	○
	16ER1.5ISO-CY	1.5	9.525	1	0.8	0.22	3.5	4.0	60°	●	○
	16ER1.75ISO-CY	1.75	9.525	1.2	0.9	0.25	3.5	4.0	60°	●	○
	16ER2.0ISO-CY	2.0	9.525	1.3	1	0.29	3.5	4.0	60°	●	○
	16ER2.5ISO-CY	2.5	9.525	1.5	1.2	0.36	3.5	4.0	60°	●	○
	16ER3.0ISO-CY	3.0	9.525	1.5	1.2	0.44	3.5	4.0	60°	●	○
	22ER3.5ISO-CY	3.5	12.7	2.3	1.6	0.45	4.71	5.0	60°	●	○
	22ER4.0ISO-CY	4.0	12.7	2.3	1.6	0.52	4.71	5.0	60°	●	○
	22ER4.5ISO-CY	4.5	12.7	2.4	1.7	0.58	4.71	5.0	60°	●	○
	22ER5.0ISO-CY	5.0	12.7	2.5	1.7	0.63	4.71	5.0	60°	●	○
	22ER5.5ISO-CY	5.5	12.7	2.7	1.9	0.72	4.71	5.0	60°	●	○
	22ER6.0ISO-CY	6.0	12.7	2.7	1.9	0.78	4.71	5.0	60°	●	○

● Ready Stock    ○ Available for Production

### ISO Metric Thread, 60° Thread Profile

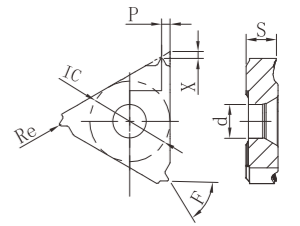

#### INTERNAL THREAD

Shape	Type	Pitch/Threads Per Inch	Basic Dimension (mm)							PVD Grade	
			IC	P	X	Re	S	d	F	CM7125A	CM7215
	11IR1.0ISO-CY	1.0	6.35	0.7	0.8	0.07	3	3.2	60°	●	○
	11IR1.25ISO-CY	1.25	6.35	0.9	0.8	0.09	3	3.2	60°	●	○
	11IR1.5ISO-CY	1.5	6.35	1	0.8	0.11	3	3.2	60°	●	○
	11IR1.75ISO-CY	1.75	6.35	1.1	0.9	0.13	3	3.2	60°	●	○
	11IR2.0ISO-CY	2.0	6.35	1.1	0.9	0.15	3	3.2	60°	●	○
	16IR1.0ISO-CY	1.0	9.525	1	0.8	0.07	3.5	4.0	60°	●	○
	16IR1.25ISO-CY	1.25	9.525	0.9	0.8	0.09	3.5	4.0	60°	●	○
	16IR1.5ISO-CY	1.5	9.525	1	0.8	0.11	3.5	4.0	60°	●	○
	16IR1.75ISO-CY	1.75	9.525	1.2	0.9	0.13	3.5	4.0	60°	●	○
	16IR2.0ISO-CY	2.0	9.525	1.3	1	0.15	3.5	4.0	60°	●	○
	16IR2.5ISO-CY	2.5	9.525	1.5	1.2	0.18	3.5	4.0	60°	●	○
	16IR3.0ISO-CY	3.0	9.525	1.5	1.2	0.22	3.5	4.0	60°	●	○
	22IR3.5ISO-CY	3.5	12.7	2.3	1.6	0.45	4.71	5.0	60°	●	○
	22IR4.0ISO-CY	4.0	12.7	2.3	1.6	0.52	4.71	5.0	60°	●	○
	22IR4.5ISO-CY	4.5	12.7	2.4	1.6	0.58	4.71	5.0	60°	●	○
	22IR5.0ISO-CY	5.0	12.7	2.3	1.6	0.63	4.71	5.0	60°	●	○
	22IR5.5ISO-CY	5.5	12.7	2.3	1.6	0.72	4.71	5.0	60°	●	○
	22IR6.0ISO-CY	6.0	12.7	2.4	1.6	0.78	4.71	5.0	60°	●	○

● Ready Stock    ○ Available for Production



## General-Purpose Thread

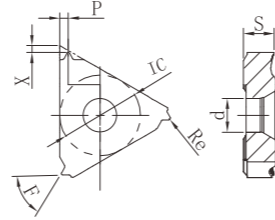

### EXTERNAL THREAD

Shape	Type	Pitch/Threads Per Inch	Basic Dimension (mm)							PVD Grade	
			IC	P	X	Re	S	d	F	CM7125A	CM7215
	16ERA55-CY	0.5-1.5	9.525	0.9	0.8	0.08	3.5	4.0	55°	●	○
	16ERAG55-CY	0.5-3.0	9.525	1.5	1.1	0.08	3.5	4.0	55°	●	○
	16ERG55-CY	1.75-3.0	9.525	1.7	1.2	0.21	3.5	4.0	55°	●	○
	16ERG60-CY	1.75-3.0	9.525	1.7	1.2	0.08	3.5	4.0	60°	●	○
	16ERA60-CY	0.5-1.5	9.525	0.9	0.8	0.08	3.5	4.0	60°	●	○
	16ERAG60-CY	0.5-3.0	9.525	1.5	1.1	0.1	3.5	4.0	60°	●	○
	22ERN55-CY	3.5-5.0	12.7	2.5	1.7	0.44	4.71	5.0	60°	●	○
	22ERN60-CY	3.5-5.0	12.7	2.5	1.7	0.51	4.71	5.0	60°	●	○

● Ready Stock ○ Available for Production

## UN (Unified National) Thread

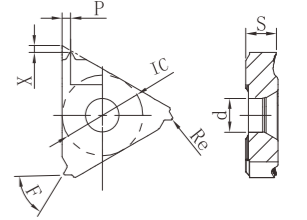

### EXTERNAL THREAD

Shape	Type	Pitch/Threads Per Inch	Basic Dimension (mm)							PVD Grade	
			IC	P	X	Re	S	d	F	CM7125A	CM7215
	16ER8UN-CY	8	9.525	1.7	1.3	0.46	3.5	4.0	60°	●	○
	16ER10UN-CY	10	9.525	1.5	1.2	0.31	3.5	4.0	60°	●	○
	16ER12UN-CY	12	9.525	1.5	1.2	0.31	3.5	4.0	60°	●	○
	16ER14UN-CY	14	9.525	1.5	1.2	0.26	3.5	4.0	60°	●	○
	16ER16UN-CY	16	9.525	1.1	0.9	0.23	3.5	4.0	60°	●	○
	16ER18UN-CY	18	9.525	1	0.8	0.2	3.5	4.0	60°	●	○
	16ER20UN-CY	20	9.525	0.9	0.8	0.18	3.5	4.0	60°	●	○
	16ER24UN-CY	24	9.525	0.8	0.8	0.15	3.5	4.0	60°	●	○

● Ready Stock ○ Available for Production

### INTERNAL THREAD

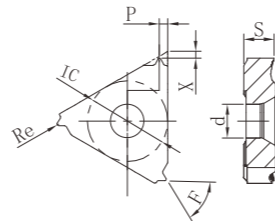

Shape	Type	Pitch/Threads Per Inch	Basic Dimension (mm)							PVD Grade	
			IC	P	X	Re	S	d	F	CM7125A	CM7215
	08IRA60-CY	0.5-1.5	5.0	0.8	0.8	0.1	2.3	2.8	60°	●	○
	11IRA55-CY	0.5-1.5	6.35	0.9	0.8	0.08	3	3.2	55°	●	○
	11IRA60-CY	0.5-1.5	6.35	0.9	0.8	0.1	3	3.2	60°	●	○
	16IRA55-CY	0.5-1.5	9.525	0.9	0.8	0.08	3.5	4.0	55°	●	○
	16IRAG55-CY	0.5-3.0	9.525	1.5	1.1	0.08	3.5	4.0	55°	●	○
	16IRG55-CY	1.75-3.0	9.525	1.7	1.2	0.21	3.5	4.0	55°	●	○
	16IRA60-CY	0.5-1.5	9.525	1.5	1.1	0.08	3.5	4.0	60°	●	○
	16IRG60-CY	1.75-3.0	9.525	1.5	1.1	0.10	3.5	4.0	60°	●	○
	16IRAG60-CY	0.5-3.0	9.525	1.5	1.1	0.10	3.5	4.0	60°	●	○

● Ready Stock ○ Available for Production

### INTERNAL THREAD

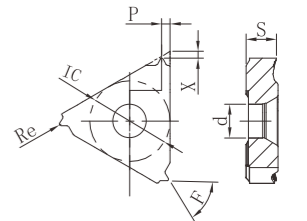

Shape	Type	Pitch/Threads Per Inch	Basic Dimension (mm)							PVD Grade	
			IC	P	X	Re	S	d	F	CM7125A	CM7215
	11IR20UN-CY	20	6.35	0.9	0.8	0.09	3	3.2	60°	●	○
	11IR18UN-CY	18	6.35	1	0.8	0.1	3	3.2	60°	●	○
	16IR8UN-CY	8	9.525	1.7	1.3	0.23	3.5	4.0	60°	●	○
	16IR10UN-CY	10	9.525	1.5	1.2	0.19	3.5	4.0	60°	●	○
	16IR12UN-CY	12	9.525	1.5	1.3	0.16	3.5	4.0	60°	●	○
	16IR14UN-CY	14	9.525	1.5	1.2	0.13	3.5	4.0	60°	●	○
	16IR16UN-CY	16	9.525	1.1	0.9	0.12	3.5	4.0	60°	●	○
	16IR18UN-CY	18	9.525	1	0.8	0.1	3.5	4.0	60°	●	○
	16IR20UN-CY	20	9.525	0.9	0.8	0.09	3.5	4.0	60°	●	○
	16IR24UN-CY	24	9.525	0.8	0.8	0.08	3.5	4.0	60°	●	○

● Ready Stock ○ Available for Production

### Whitworth Thread

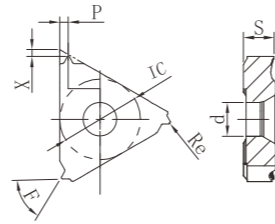

#### EXTERNAL THREAD

Shape	Type	Pitch/Threads Per Inch	Basic Dimension (mm)							PVD Grade	
			IC	P	X	Re	S	d	F	CM7125A	CM7215
	16ER10W-CY	10	9.525	1.5	1.1	0.34	3.5	4.0	55°	●	○
	16ER11W-CY	11	9.525	1.5	1.1	0.23	3.5	4.0	55°	●	○
	16ER12W-CY	12	9.525	1.5	1.2	0.28	3.5	4.0	55°	●	○
	16ER14W-CY	14	9.525	1.2	1.0	0.2	3.5	4.0	55°	●	○
	16ER16W-CY	16	9.525	1.1	0.9	0.2	3.5	4.0	55°	●	○
	16ER18W-CY	18	9.525	1	0.8	0.18	3.5	4.0	55°	●	○
	16ER19W-CY	19	9.525	1	0.8	0.17	3.5	4.0	55°	●	○

● Ready Stock ○ Available for Production

### American Standard Pipe Thread

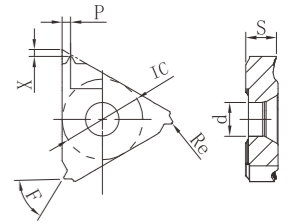

#### EXTERNAL THREAD

Shape	Type	Pitch/Threads Per Inch	Basic Dimension (mm)							PVD Grade	
			IC	P	X	Re	S	d	F	CM7125A	CM7215
	16ER8NPT-CY	8	9.525	1.8	1.3	0.3	3.5	4.0	60°	●	○
	16ER11.5NPT-CY	12	9.525	1.5	1.1	0.25	3.5	4.0	60°	●	○
	16ER14NPT-CY	14	9.525	1.5	1.2	0.22	3.5	4.0	60°	●	○
	16ER18NPT-CY	18	9.525	1	0.8	0.2	3.5	4.0	60°	●	○
	16ER27NPT-CY	27	9.525	0.8	0.7	0.1	3.5	4.0	60°	●	○

● Ready Stock ○ Available for Production

#### INTERNAL THREAD

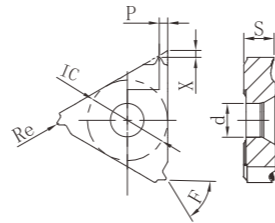

Shape	Type	Pitch/Threads Per Inch	Basic Dimension (mm)							PVD Grade	
			IC	P	X	Re	S	d	F	CM7125A	CM7215
	11R14W-CY	14	6.35	1.1	0.9	0.25	3	3.2	55°	●	○
	11R19W-CY	19	6.35	1	0.9	0.19	3	3.2	55°	●	○
	16R8W-CY	8	9.525	1.5	1.2	0.41	3.5	4.0	55°	●	○
	16R11W-CY	11	9.525	1.5	1.1	0.3	3.5	4.0	55°	●	○
	16R12W-CY	12	9.525	1.5	1.2	0.28	3.5	4.0	55°	●	○
	16R14W-CY	14	9.525	1.2	1.0	0.2	3.5	4.0	55°	●	○
	16R16W-CY	16	9.525	1.1	0.9	0.2	3.5	4.0	55°	●	○
	16R18W-CY	18	9.525	1	0.8	0.18	3.5	4.0	55°	●	○
	16R19W-CY	19	9.525	1	0.8	0.17	3.5	4.0	55°	●	○

● Ready Stock ○ Available for Production

#### INTERNAL THREAD

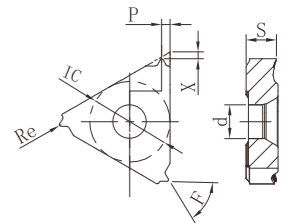

Shape	Type	Pitch/Threads Per Inch	Basic Dimension (mm)							PVD Grade	
			IC	P	X	Re	S	d	F	CM7125A	CM7215
	11RM18NPT-CY	18	6.35	1	0.8	0.2	3.5	4.0	60°	●	○
	16R8NPT-CY	8	9.525	1.8	1.3	0.3	3.5	4.0	60°	●	○
	16R11.5NPT-CY	12	9.525	1.5	1.1	0.25	3.5	4.0	60°	●	○
	16R14NPT-CY	14	9.525	1.5	1.2	0.22	3.5	4.0	60°	●	○
	16R18NPT-CY	18	9.525	1	0.8	0.2	3.5	4.0	60°	●	○

● Ready Stock ○ Available for Production

### British Standard Pipe Thread

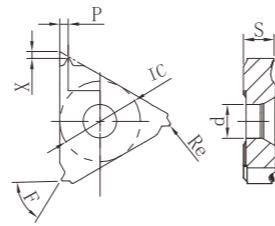

#### EXTERNAL THREAD

Shape	Type	Pitch/Threads Per Inch	Basic Dimension (mm)							PVD Grade	
			IC	P	X	Re	S	d	F	CM7125A	CM7215
	16ER11BSPT-CY	11	9.525	1.5	1.1	0.3	3.5	4.0	60°	●	○
	16ER14BSPT-CY	14	9.525	1.2	1.0	0.24	3.5	4.0	60°	●	○
	16ER19BSPT-CY	19	9.525	1	0.8	0.17	3.5	4.0	60°	●	○
	16ER28BSPT-CY	28	9.525	0.8	0.7	0.11	3.5	4.0	60°	●	○

● Ready Stock ○ Available for Production

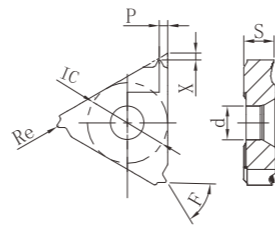

#### INTERNAL THREAD

Shape	Type	Pitch/Threads Per Inch	Basic Dimension (mm)							PVD Grade	
			IC	P	X	Re	S	d	F	CM7125A	CM7215
	11IRM14BSPT-CY	14	6.35	1.1	0.9	0.24	3	3.2	60°	●	○
	11IRM19B-CY	19	6.35	1	0.8	0.18	3	3.2	60°	●	○
	16IR11BSPT-CY	11	9.525	1.5	1.1	0.3	3.5	4.0	60°	●	○
	16IR14BSPT-CY	14	9.525	1.2	1.0	0.24	3.5	4.0	60°	●	○
	16IR19BSPT-CY	19	9.525	1	0.8	0.17	3.5	4.0	60°	●	○
	16IR28BSPT-CY	28	9.525	0.8	0.7	0.11	3.5	4.0	60°	●	○

● Ready Stock ○ Available for Production

### Cermet Turning Inserts

- ▶ Negative Cermet Turning Inserts
- ▶ Positive Cermet Turning Inserts

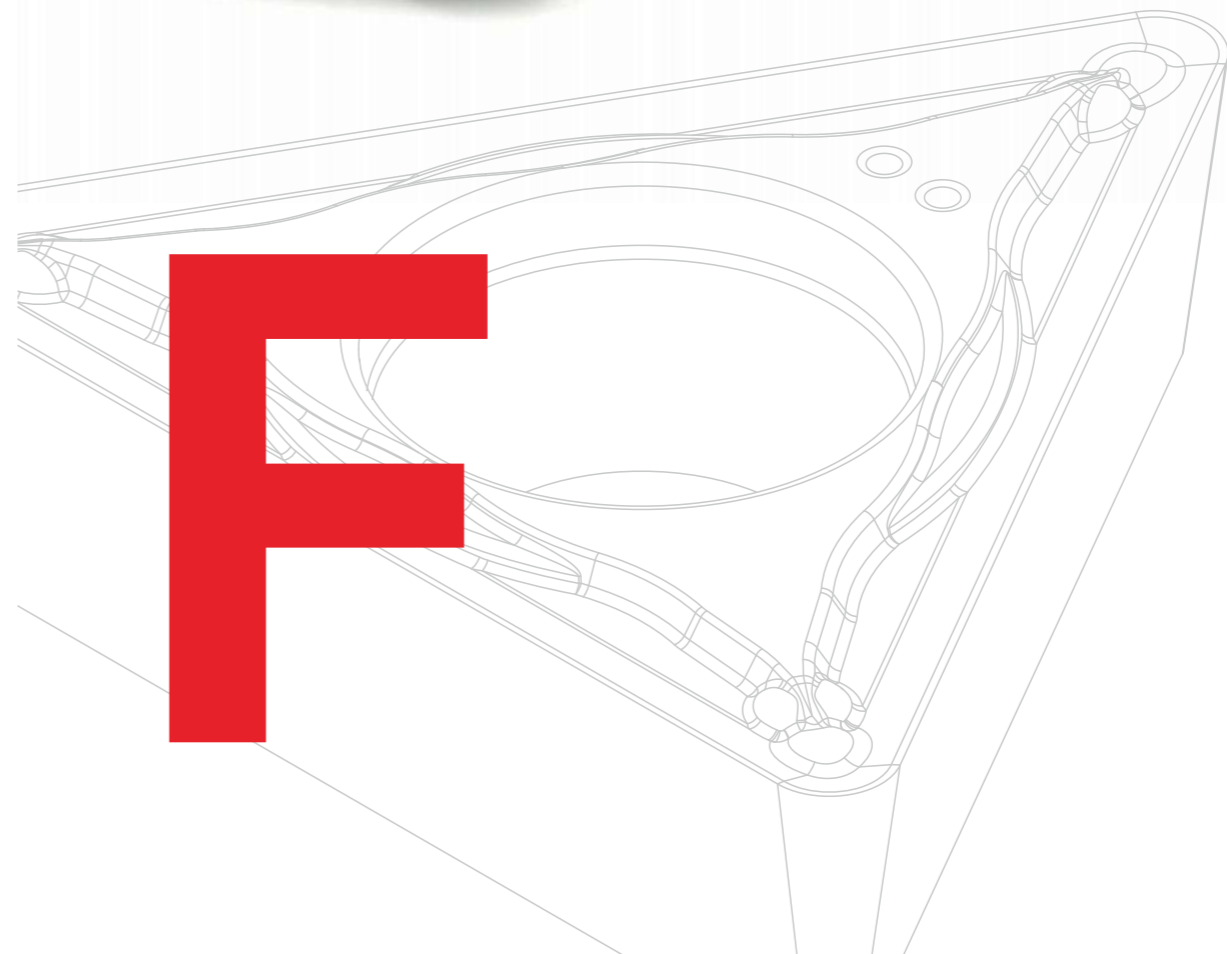

### Negative Cermet Turning Inserts

Shape	Type	Basic Dimension (mm)					PVD			
		L	IC	S	d	Re	CMT55	CMT80A	CP55TM	CP80TM
	CNMG120404-MM	12.9	12.7	4.76	5.16	0.4	○	●	●	●
	CNMG120408-MM	12.9	12.7	4.76	5.16	0.8	○	●	●	●
	CNMG120412-MM	12.9	12.7	4.76	5.16	1.2	○	●	●	●
	DNMG110404-MM	11.6	9.525	4.76	3.81	0.4	○	●	●	●
	DNMG110408-MM	11.6	9.525	4.76	3.81	0.8	○	●	●	●
	DNMG150404-MM	15.5	12.7	4.76	5.16	0.4	○	●	●	●
	DNMG150408-MM	15.5	12.7	4.76	5.16	0.8	○	●	●	●
	DNMG150412-MM	15.5	12.7	4.76	5.16	1.2	○	●	●	●
	DNMG150604-MM	15.5	12.7	6.35	5.16	0.4	○	●	●	●
	SNMG120404-MM	12.7	12.7	4.76	5.16	0.4	○	●	●	●
	SNMG120408-MM	12.7	12.7	4.76	5.16	0.8	○	●	●	●
	SNMG120412-MM	12.7	12.7	4.76	5.16	1.2	○	●	●	●
	SNMG150608-MM	15.875	15.875	6.35	6.35	0.8	○	●	●	●
	TNMG160404-MM	16.5	9.525	4.76	3.81	0.4	○	●	●	●
	TNMG160408-MM	16.5	9.525	4.76	3.81	0.8	○	●	●	●
	TNMG160412-MM	16.5	9.525	4.76	3.81	1.2	○	●	●	●
	TNMG220404-MM	22	12.7	4.76	5.16	0.4	○	●	●	●
	VNMG160404-MM	16.6	9.525	4.76	3.81	0.4	○	●	●	●
	VNMG160408-MM	16.6	9.525	4.76	3.81	0.8	○	●	●	●
	VNMG160412-MM	16.6	9.525	4.76	3.81	1.2	○	●	●	●
	WNMG060408-MM	6.5	9.525	4.76	3.81	0.8	○	●	●	●
	WNMG060412-MM	6.5	9.525	4.76	3.81	1.2	○	●	●	●
	WNMG080404-MM	8.7	12.7	4.76	5.16	0.4	○	●	●	●
	WNMG080408-MM	8.7	12.7	4.76	5.16	0.8	○	●	●	●
	WNMG080412-MM	8.7	12.7	4.76	5.16	1.2	○	●	●	●

● Ready Stock ○ Available for Production

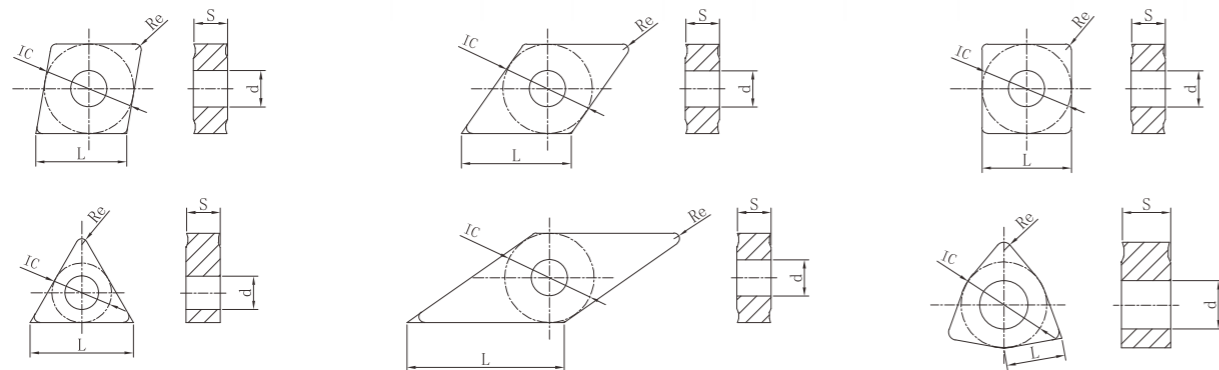

### Positive Cermet Turning Inserts

Shape	Type	Basic Dimension (mm)					PVD			
		L	IC	S	d	Re	CMT55	CMT80A	CP55TM	CP80TM
	CCMT060204-MM	6.4	6.35	2.38	2.8	0.4	○	●	●	●
	CCMT060208-MM	6.4	6.35	2.38	2.8	0.8	○	●	●	●
	CCMT09T304-MM	9.7	9.525	3.97	4.4	0.4	○	●	●	●
	CCMT09T308-MM	9.7	9.525	3.97	4.4	0.8	○	●	●	●
	CCMT120404-MM	12.9	12.7	4.76	5.16	0.4	○	●	●	●
	CCMT120408-MM	12.9	12.7	4.76	5.16	0.8	○	●	●	●
	DCMT120412-MM	12.9	12.7	4.76	5.16	1.2	○	●	●	●
	DCMT070204-MM	7.8	6.35	2.38	2.8	0.4	○	●	●	●
	DCMT070208-MM	7.8	6.35	2.38	2.8	0.8	○	●	●	●
	DCMT11T304-MM	11.6	9.525	3.97	4.4	0.4	○	●	●	●
	DCMT11T308-MM	11.6	9.525	3.97	4.4	0.8	○	●	●	●
	SCMT09T304-MM	9.525	9.525	3.97	4.4	0.4	○	●	●	●
	SCMT09T308-MM	9.525	9.525	3.97	4.4	0.8	○	●	●	●
	SCMT120404-MM	12.7	12.7	4.76	5.56	0.4	○	●	●	●
	SCMT120408-MM	12.7	12.7	4.76	5.56	0.8	○	●	●	●
	SCMT120412-MM	12.7	12.7	4.76	5.56	1.2	○	●	●	●
	TCMT110204-MM	11	6.35	2.38	2.8	0.4	○	●	●	●
	TCMT110208-MM	11	6.35	2.38	2.8	0.8	○	●	●	●
	TCMT16T304-MM	16.5	9.525	3.97	4.4	0.4	○	●	●	●
	TCMT16T308-MM	16.5	9.525	3.97	4.4	0.8	○	●	●	●
	VCMT110304-MM	11	6.35	3.18	2.8	0.4	○	●	●	●
	VCMT110308-MM	11	6.35	3.18	2.8	0.8	○	●	●	●
	VBMT160404-MM	16.5	9.525	4.76	4.4	0.4	○	●	●	●
	VBMT160408-MM	16.5	9.525	4.76	4.4	0.8	○	●	●	●
	VBMT160412-MM	16.5	9.525	4.76	4.4	1.2	○	●	●	●

● Ready Stock ○ Available for Production

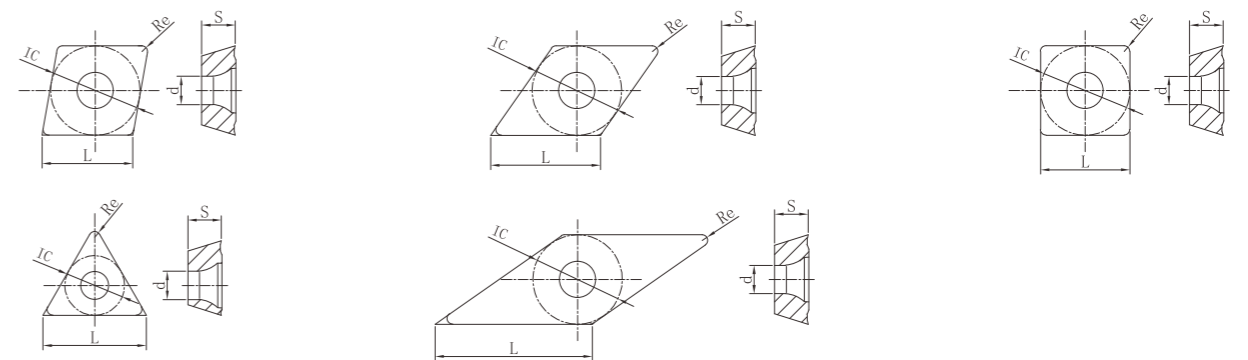

## General Technical Information

- ▶ Selection Method of Cutting Tools
- ▶ Carbide Products Safety Standard
- ▶ Safety Problems and Protective Measures
- ▶ Inserts Metric and Inch Comparison Table
- ▶ Chipbreaker Comparison Table
- ▶ Grade Comparison Table
- ▶ Material Comparison Table
- ▶ Hardness Comparison Table



# G

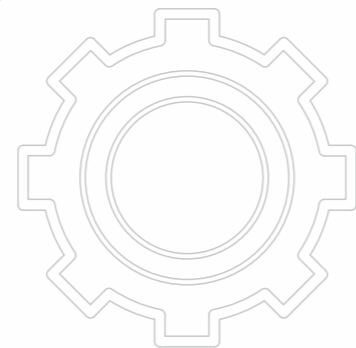

## Selection Method of Cutting Tools

### Selection of Turning Tools:

1. Understanding of workpiece material, machine model and process status.
2. Select the inserts configuration, cutting main deflection angle and clamping method.
3. Confirm the left and right directions and dimensions of the holder.
4. Determine the insert type.

### Selection of Milling Tools:

1. Understanding of workpiece material, machine model and process status.
2. Confirm machining type. (face milling, square shoulder milling, profiling milling, slot milling.)
3. Determine to use solid end mill or indexable milling inserts.
4. Determine the interface and size of the milling tools.
5. Determine the insert type.

### Selection of Drilling Tools:

1. Understanding of workpiece material, machine model and process status.
2. Determine the basic types of tools. (drilling, boring, reaming, threading, etc.)
3. Determine to use integrated drilling or indexable drilling tool.
4. Determine the interface and size of the tool.
5. Determine the insert type.

## Carbide Products Safety Standard

### Safety Responsibility

Before using products by CY Carbide MFG. CO., LTD., the operator shall have necessary safety training and read safety precautions on the product package carefully. The company will not take any legal responsibility for any loss caused by not using and operating according to relevant requirements.

### Precautions for Use of Cemented Carbide Tools

1. Cemented carbide edge is sharp, material hardness is high, and it is relatively brittle. Large force can cause brittle fracture and damage.
2. Chips are inevitably generated in the cutting process. Operators must wear protective clothing, protective glasses and other labor protection articles.
3. The density of cemented carbide is high. The handling and storage shall be treated as heavy objects and handle with care.
4. Hard alloy tools shall be stored in a dry and non-corrosive atmosphere.
5. The thermal expansion coefficient of cemented carbide is different from that of steel. Welding shall be carried out at appropriate temperature to avoid welding cracks caused by concentrated stress.
6. In order to improve the service life of the machine tool and cutting tool, please select the cooling mode correctly.
7. Do not continue to use the tool with cracks during processing and production.
8. Please recycle and keep the worn and replaced cemented carbide tools and fragments to avoid injury caused by others.

## Safety Problems and Protective Measures

Possible Safety Issues	Protective Measures
When cutting, clothing, gloves, and long hair are easily entangled in to the high speed running machine.	<ul style="list-style-type: none"> <li>• Do not wear gloves to operate when rotary cutting.</li> <li>• Please hide your long hair in the work cap.</li> <li>• Always pay attention not to let clothes contact rotating parts.</li> </ul>
Improper use of cutting tools can damage itself, accessories fly out and cause injuries.	<ul style="list-style-type: none"> <li>• Read the catalogue and safety standards before use.</li> <li>• Please wear safety glasses and protective clothing.</li> </ul>
Direct contact with the sharp edge of the tool may cause human body injuries.	<ul style="list-style-type: none"> <li>• Please wear gloves and other labor protection appliances when loading and unloading cutting tools.</li> </ul>
Chips during cutting may cause scratches and scalds to human body.	<ul style="list-style-type: none"> <li>• Use cleaning instruments to remove chips in time.</li> <li>• Please wear protective glasses, protective clothing and gloves.</li> </ul>
The burr and other defects on the processed part are very sharp and easy to scratch the human body.	<ul style="list-style-type: none"> <li>• Do not touch the burr and other defects on the machined part.</li> <li>• Please wear protective clothing, gloves and other labor protection appliances.</li> </ul>
If the machined part is directly cut without clamping, it will cause damage to the tool and spatter of the machined part.	<ul style="list-style-type: none"> <li>• The machined part must be clamped.</li> <li>• Please wear protective glasses, protective clothing and gloves.</li> </ul>
If the insert or its accessories are not clamped properly, the cutting tool may fall off and fly out, causing injuries.	<ul style="list-style-type: none"> <li>• Before machining, make sure that the insert and other accessories have been fastened properly with proper tools.</li> </ul>
During high-speed cutting, chips flying out at a high speed may cause injuries.	<ul style="list-style-type: none"> <li>• Use safety cover, protective screen, outer cover, etc.</li> <li>• Please wear protective glasses, protective clothing and gloves.</li> </ul>
When the insert or its accessories are at a high speed, they may fall off and fly out under the action of inertial centrifugal force, thus cause injuries.	<ul style="list-style-type: none"> <li>• Please use cutting tools according to the range recommendation.</li> <li>• Please wear safety glasses and protective clothing.</li> </ul>

## Safety Problems and Protective Measures

Possible Safety Issues	Protective Measures
The edge of the milling cutting tools is sharp, and direct touch by hands may cause scratches.	<ul style="list-style-type: none"> <li>When touching cutting tools, please wear gloves and other labor protection appliances.</li> </ul>
Excessive wear and severe impact increase the cutting resistance, which may break the tool to splash, and lead injuries to the operator as a result.	<ul style="list-style-type: none"> <li>Replace excessively worn cutting tools in time.</li> <li>Please wear safety glasses and protective clothing.</li> </ul>
Sparks and high temperature chips generated during cutting may cause fire and explosion.	<ul style="list-style-type: none"> <li>Remove flammable and explosive materials in the cutting area.</li> <li>Prepare fire-fighting equipment.</li> </ul>
Poor balance of the fixtures will cause severe vibration to running machines at a high speed, and as a result damage the cutting tools.	<ul style="list-style-type: none"> <li>Before cutting, check looseness or abnormal sound of the equipment.</li> <li>Please wear safety glasses and protective clothing.</li> </ul>
When the auxiliary tools such as bolt or pressing plate are over tightened, the insert or the tool may be damaged and splashed.	<ul style="list-style-type: none"> <li>Do not over tighten by auxiliary tools such as sleeves.</li> </ul>
The tools with eccentric rotation or poor balance may shake or vibrate during rotary processing, which may cause damage and scattering.	<ul style="list-style-type: none"> <li>Please use the tool within the speed range allowance.</li> <li>Regularly check the balance performance of the machine.</li> </ul>
When drilling with extremely small cutting tools, it is easy to break the tools, splash and failure to take out.	<ul style="list-style-type: none"> <li>Reduce the vibration of the tool and process at a suitable running speed.</li> <li>Please wear protective glasses, protective clothing and gloves.</li> </ul>
Violating the regulations to use the tool will increase wear of machine and cutting tools, and cause other hazards.	<ul style="list-style-type: none"> <li>Please use according to the instructions and regulations.</li> </ul>





**Remark: The accident caused by tools or using it for other purposes without our permission shall be borne by yourselves.**

## Inserts Metric and Inch Comparison Table

Negative C	ISO	Inch
	090304	321
	090308	322
	120404	431
	120408	432
	120412	433
	120416	434
	160608	542
	160612	543
	160616	544
	190608	642
	190612	643
	190616	644
	190624	646
	250724	856
	250732	858
	250924	866
	250932	868

Negative D	ISO	Inch
	110404	331
	110408	332
	110412	333
	150404	431
	150408	432
	150412	433
	150604	441
	150608	442
	150612	443
	150616	444
	190608	542
	190612	543

Negative R	ISO	Inch
	0903MO	32
	1204MO	43

Negative V	ISO	Inch
	160404	331
	160408	332
	160412	333

Negative C	ISO	Inch
	090304	321
	090308	322
	090312	323
	120404	431
	120408	432
	120412	433
	120416	434
	160608	542
	160612	543
	160616	544
	190412	633
	190424	636
	190612	643
	190616	644
	250724	856
	250732	858
	250924	866
	250932	868

Negative T	ISO	Inch
	110304	221
	110308	222
	160404	331
	160408	332
	160412	333
	220404	431
	220408	432
	220412	433
	220416	434
	270608	542
	270612	543
	270616	544

Negative W	ISO	Inch
	06T304	3(2.5)1
	06T308	3(2.5)2
	06T312	3(2.5)3
	060404	331
	060408	332
	060412	333
	080404	431
	080408	432
	080412	433

### Inserts Metric and Inch Comparison Table

Positive C	ISO	Inch
	060202	2(1.5)0
	060204	2(1.5)1
	060208	2(1.5)2
	09T302	3(2.5)0
	09T304	3(2.5)1
	09T308	3(2.5)2
	120404	431
	120408	432
	120412	433

Positive D	ISO	Inch
	070202	2(1.5)0
	070204	2(1.5)1
	070208	2(1.5)2
	11T302	3(2.5)0
	11T304	3(2.5)1
	11T308	3(2.5)2
	11T312	3(2.5)3

Positive S	ISO	Inch
	060204	2(1.5)1
	09T302	3(2.5)0
	09T304	3(2.5)1
	09T308	3(2.5)2
	120404	431
	120408	432
	120412	433
	150404	531
	150408	532
	150412	533
	190408	632
	190412	633
	190416	634

Positive T	ISO	Inch
	06T102	1.2(1.2)0
	06T104	1.2(1.2)1
	06T108	1.2(1.2)2
	090202	1.8(1.5)0
	090204	1.8(1.5)1
	090208	1.8(1.5)2
	110202	2(1.5)0
	110204	2(1.5)1
	110208	2(1.5)2
	110302	220
	110304	221
	110308	222
	16T302	3(2.5)0
	16T304	3(2.5)1
	16T308	3(2.5)2
	16T312	3(2.5)3
	160400	330
	220408	432
	220412	433
	220416	434
	270408	532
	270412	533
	330612	643
	330616	644

Positive V	ISO	Inch
	110202	2(1.5)0
	110204	2(1.5)1
	110208	2(1.5)2
	110302	220
	110304	221
	110308	222
	160402	330
	160404	331
	160408	332
	160412	333

### Chipbreaker Comparison Table

#### Negative Inserts

ISO	PROCESSING CATEGORY	CYCT	TaeguTec	KENNAMETAL	HITACHI	ZCCCT	SANDVIK	TUNGALOY	KYOCERA	KORLOY	SUMITOMO	MISTUBISHI
P	Finishing	PF	FG,FA	LF,FN	BE,CE,BH	DF	XF,PF,MF	TSFASNS,27	HQ,CQ,CJ, PQ,VF,GP	HF	SU,LU,SX, SP,FP,FA, FL,SE,STC	C,SA, SH,LP
	Finishing (WIPER)		WS,EA, WT,MG	FW,MW,RW		WG	WPWF, WM,WMX	AFW,ASW	WP,WQ	HW	LUW,SEW, GUW	SW,MW
	Semi-Finishing	PM	ML,ET,MP, MC,SM,MT	MN,P,MG	AB,AY AR, AH,CT	DM,PM	PM,QM, SM,XM	TM,DM,ZM, NM,33,38,37, TH,32Y,32,37	CJ,GS,HK, PS,HS,PT,CS	HC,HM,HA	GU,UG,UX, GE,UA,UM	MV,MP,MZ, MA,MH
	Roughing	PH	RT,RH,HT	MR,RMn, RH,PR,MG	HX,HE,H	DR,HDR	QR,MR,PR, HR,23	57,65,TU31, 33,F-K THS	HX,PX,PH	HR,HH	MP,HG,HP, MC,MU, MX,UZ	HZ,HX,HVHZ, HXD,HA,HAS, HBS,HCS, HDS,HXD
M	Finishing	MF	FG,SF	K,FP	MP,SE	EF	MF	SS	GU,MQ	HA	SU	FS,SH, J,LM
	Semi-Finishing	MM,MQ, CM	ML,MP, EM,VF	P,MP	PV,DE,AH	EM	MM,K	SA,SMS,SF	SU,HU,MU, MS,ST,TK	HS	EX,UP,MU, HM,GU	M,ES,MA, MJ,MH,GM, MM,ES,2G
	Roughing		TRH	UP,RP		ER	MR	TH,SH		GS,HM	MP,MU, HP,HG	GH,HZ,RM
K	Finishing		FG	FN	VA,AH	PM	KF	Y,CF		WITHOUT CHIPBREAKER	UZ	ALL-ROUND CHIPBREAKER, MA
	Semi-Finishing	KM	MC,MT,MG	ALL-ROUND CHIPBREAKER, PUN,UM,RP	YV	PM	KM	ALL-ROUND CHIPBREAKER, CF,CM,33	ZS,C, ALL-ROUND CHIPBREAKER	ALL-ROUND CHIPBREAKER	UX,GZ, UX,UJ	ALL-ROUND CHIPBREAKER
	Roughing	CK	RH,RT	UN,MG		WITHOUT CHIPBREAKER	KR	CH	WITHOUT CHIPBREAKER GC	HR,GH,GR	WITHOUT CHIPBREAKER, UZ,MU,MM	WITHOUT CHIPBREAKER

#### Positive Inserts

ISO	PROCESSING CATEGORY	CYCT	TaeguTec	KENNAMETAL	HITACHI	ZCCCT	SANDVIK	TUNGALOY	KYOCERA	KORLOY	SUMITOMO	MISTUBISHI
P	Finishing	PF	FA,FG	11,UF, GF,L,FP	JQ	SF,HF	UF,PF	01,PF, FS,JS	GP,CK,XPVF, CF,GQ,GF	HFP	FP,LU,FC, SU,SK,FK	FV,SV,FP, SQ,SMG
	Semi-Finishing	PM	MT,CMX	MF,MP	JE	HM	UM,W,FP,PM	PM,PS,PF, PSF,PSS, 23,24	HQ,XQ,GK	HMP,C25	MU,SC	MV,MQ,AM,MP, ALL-ROUND CHIPBREAKER
M	Finishing	MF	FA,FG	FW,MW,FP	MP	EF	MF	SS&	CF,CK,GQ, GF,DP	HFP	LU	SV,FV
	Semi-Finishing	MM	MT,CMX	MP		EM	MM	PM	HQ,GK	HMP,C25		FM,MV,LM, ALL-ROUND CHIPBREAKER
K	Semi-Finishing	KM	MT,CMX			WITHOUT CHIPBREAKER, HR,HM	KM,KR,KF	WITHOUT CHIPBREAKER, CM	WITHOUT CHIPBREAKER	HMP,C25	WITHOUT CHIPBREAKER	WITHOUT CHIPBREAKER
N	GENERAL CUTTING		FL	HP		LH	AL	PP,AL	A3,AH	TA,AK	AG,AW,FY	AZ

### Grade Comparison Table

Category	ISO Code	CYCT	TaeguTec	KENNAMETAL	HITACHI	ZCCCT	SANDVIK	TUNGALOY	KYOCERA	KORLOY	SUMITOMO
CVD	P01			KCP05 KC9105	HC5000 HG8010		GC4005 GC4205	T9005 T9105	CA5505		AC700G AC810P
	P10	CP8115S CP8115	TT8115	KCP10 KCP25 KC9110	HG8010 HG8020 GM8015 GM10	YBC151 YBC152	GC4015 GC4215	T9005 T9105 T9115	CA5505 CA5515	NC3010 NC3015	AC810P AC820P
	P20	CP8125S CP8125	TT5100 TT8125	KCP25 KC9125 KC9225	HG8025 GM8020 GM25	YBC251 YBC252	GC4015 GC4025 GC4225 GC2015	T9115 T9015 T9025 T9125	CA5515 CA5525 CA5025 CR9025	NC3020 NC3120	AC820P
	P30	CP8125S CP8035S	TT8125 T5100	KCP30 KCP40 KC8050	GM8035 GM25	YBC252 YBC351	GC4025 GC4225 GC4035 GC2025 GC4235	T9025 T9035 T9135 T9125	CA5525 CA5535 CR9025	NC3030	AC630M AC830P
	P40	CP8035	TT8135 TT7100	KC9140 KC9040 KC9240 KX9245 TN7035 TPC35	GM8035 GX30	YBC151 YBC352	GC4035 GC235 GC4235	T9035 T9135	CA5535	NC500H	AC610M
	K01	CK6105	TT7005	KCK05	HX3505 HG3305 GM3005	YBD052	GC3205 GC3210	T5105 T5010	CA4010 CA4505	NC6015	AC405K AC410K
	K10	CK6115 CK6115D	TT7015	KCK15 KCK20 KC9315	HX3515 HG3315 HG8010 GM8015	YBD102 YBD152 YBD152C	GC3205 GC3210 GC3215	T5010 T1115 T5115	CA4515 CA4010 CA4115	N305K NC6010 NC6110	AC415K
	K20		TT7105 TT7310 TT1500	KCK20 KC9110 KC9320	HG8025 GM8020	YBD152	GC3215	T5115 T5125 T5020	CA4515 CA4115 CA4120	N315K NC5330 PC5300 NC6010	AC420K AC700G
	K30			KC9125 KC9325		YBD252		T5125 T9125			AC820P

### Grade Comparison Table

Category	ISO Code	CYCT	TaeguTec	KENNAMETAL	HITACHI	ZCCCT	SANDVIK	TUNGALOY	KYOCERA	KORLOY	SUMITOMO	MISTUBISHI
PVD	M10	CM7115A	TT5030	KC5010 KC5510 KC6005 KC6015	IP050S	YBG102 YBG105	GC1005 GC1025 GC1105 GC1125	AH710	PR915 PR1025 PR1215 PR1225		AC510U	VP10MF
	M20	CM7215 CM7220	TT9080	KC5025 KC730 KC5525 KC7020 KC7025	IP100S	YBG202	GC1020 GC1025 GC1125 GC4125	AH710 AH725 AH120 SH730 GH730 GH130 GH330 AH630	PR915 PR930 PR1025 PR1125 PR1215 PR1225	PC9030	AC520U	VP10RT VP20RT VP15TF VP20MF
	M30	CM7220 CM7125A		KC7030 KC7225		YBG202 YBG205 YBG302	GC1020 GC1125 GC2035	AH120 GH330 AH645 SH730 GH730	PR1125	PC9030	AC520U AC530U	VP10RT VP20RT VP15TF VP20MF
	M40	CM7125A					GC2035 GC2145		PR905 PR1215		AC530U	MP7035
	P10	CA5105	TT8020	KC5010 KC5510 KU10T		YBG202 YBG205	GC1025 GC1525	AH710	PR915 PR1005 PR930 PR1025 PR1115 PR1225			VP10MF
	P20	CA5120	TT6080	KC5025 KC5525 KC7215 KC7315 KU25T	IP2000	YBG102 YBG105	GC1020 GC1025 GC1525 GC1125	Ah710 AH330 AH725 AH120 SH730 GH730 GH130	PR930 PR1025 PR1115 PR1225	PC230		VP10RT VP20RT VP15TF VP20MF
	P30	CA5125		KC7015 KC7020 KC7035 KU25T	IP3000	YBG202 YBG302	GC1025 GC4125 GC1125	AH710 AH330 AH725 AH120 SH730 GH730 GH130	PR930 PR1025 PR1115 PR1225	PC3535 PC3545	AC530U	VP10RT VP20RT VP15TF VP20MF
	P40		Tt8020	KC7030 KC7040 KC7140			GC1020 GC2145	AH740	PR630 PR660	PC240		VP15TF VP20MF

### Grade Comparison Table

Category	ISO Code	CYCT	TaeguTec	KENNAMETAL	HITACHI	ZCCCT	SANDVIK	TUNGALOY	KYOCERA	KORLOY	SUMITOMO	MITSUBISHI	
PVD	M10	CA5110	TT5030	KC5010 KC5510 KC6005 KC6015	IP050S	YBG102 YBG105	GC1005 GC1025 GC1105 GC1125	AH710	PR915 PR1025 PR1215 PR1225		AC510U	VP10MF	
	M20	CA5120	TT9080	KC5025 KCT30 KC5525 KC7020 KC7025	IP100S	YBG202	GC1020 GC1025 GC1125 GC4125	AH710 AH725 AH120 SH730 GH730 GH130 GH330 AH630	PR915 PR930 PR1025 PR1125 PR1215 PR1225	PC9030	AC520U	VP10RT VP20RT VP15TF VP20MF	
	M30	CA5125		KC7030 KC7225		YBG202 YBG205 YBG302	GC1020 GC1125 GC2035	AH120 GH330 AH645 SH730 GH730	PR1125	PC9030	AC520U AC530U	VP10RT VP20RT VP15TF VP20MF	
	M40		TT8020				GC2035 GC2145		PR905 PR1215		AC530U	MP7035	
	K10			KC5010 KC7210		YBG102 YBG105		AH710 GH110 AH110	PR905 PR1215	PC205K			
	K20	CK6020		KC7015 KC7020 KC7215 KC7315		YBG202	GC1020	AH110 AH710 AH725 AH120 GH110 GH730 GH130			PC215K	AC510U	VP10RT VP20RT VP15TF
	K30			KC7225			GC4125	GH730 GH130 AH725 AH120					VP10RT VP20RT VP15TF
	Cermat	P10	CMT55	CT3000	KT325 KT125		YNG151 YNG151C	CT5015	NS520 GT530 GT730 NS730	TN60 TN6020 PV60 PV7020	CC115	T1200A T2000Z	AP25N NX2525
		P10	CMT80A	CT3000	KT325 KT125		YNG151 YNG151C	CT5015	NS520 GT530 GT730 NS730	TN60 TN6020 PV60 PV7020	CC115	T1200A T2000Z	AP25N NX2525
		P10	CP80TM	CT3000								PV720	

### Material Comparison Table

#### Steel

ISO	Nations And Standard										
	CHN	GER	USA	GBR	IT	ES	SE	FR	JPN		
	GB(P)	W-nr	DIN	AISI/SAE	BS	EN	UNI	UNE	SS	AFNOR	JIS
Carbon Steel	15	1.0401	C15	1015	080M15		C15C16	F.111	1350	CC12	
	20	1.0402	C22	1020	050A20	2C	C20C21	F.112	1450	CC20	
	35	1.0501	C35	1035	060A35		C35	F.113	1550	CC35	
	45	1.0503	C45	1045	080M40		C45	F.114	1650	CC45	
	55	1.0535	C55	1055	070M55		C55		1655		
	60	1.0601	C60	1060	080A62	43D	C60			CC55	
	Y15	1.7015	9SMN28	1213	230M07		CF9SMn28	11SMn28	1912	S250	SUM22
	40Mn	1.1157	40Mn4	1039	150M36	15				35M5	
	25	1.1158	Ck25	1025	150M28						S25C
	35Mn2	1.1167	36Mn5	1335				36Mn5	2120	40Mn5	SMn438(H)
Manganese Steel	30Mn	1.117	28Mn6	1330		14A	C28Mn			20M5	SCMn1
	35Mn	1.1183	Cf35	1035	060A35		C36		1572	XS38TS	S35C
		1.0718	9SMnPb28	12L13			CF9MnPb28	11SMnPb28	1914	S250Pb	SUM22L
		1.0722	10SPb20				CF10Pb20	10SPb		10PbF2	
		1.0726	35S20	1140	212M36	8M		F210G	1957	35MF4	
	Y13	1.0736	9SMn36	1215	240M07	1B	CF9SMn36	12SMn35		S300	
		1.0737	9SMnPb36	12L14			CF9SMnPb36	12SMnPb35	1926	S300Pb	
	55Si2Mn	1.0904	55Si9	9255	250A53	45	55Si8	56Si7	2085	55S7	
		1.0961	60SiCr7	9262			60SiCr8	60Sicr8		60SC7	
	15	1.1141	Ck15	1015	080M15	32C	C16	C15K	1370	XC12	S15C
Ck45	1.1191	45	1045	080M46		C45	C45K	1672	XC42	S45C	
55	1.1203	Ck55	1055	070M55		C50	C55K		XC45	S55C	
50	1.1213	Cf53	1050	060A52		C53		1674	XC48TS	S50C	
60Mn	1.1221	Ck60	1060	080A62	43D	C60		1678	XC60	S68C	
	1.1274	Ck101	1095	060A96				1870		SUP4	
	1.3401	X120Mn12		Z120M12		XG120Mn12	X120Mn12		X120M12	SCMnH/1	
Gr15,45Gr	1.3505	100Cr6	52100	534A99	31	100Cr6	F.131	2258	100C6	SUJ2	
	1.5415	15Mo3	ASTMA204GrA	1501-240		16Mo3KW	16Mo3	2912	15D3		
	1.5426	16Mo5	4520	1503-245-420		16Mo5	16Mo5				
	1.5622	14Ni6	ASTMA350LF5			14Ni6	15Ni6		16N6		
	1.5662	X8Ni9	ASTM A353	1501-509:510		X10Ni9	XBNI09				

### Material Comparison Table

#### Steel

ISO	Nations And Standard										
	GB(P)	W-nr	DIN	AISI/SAE	BS	EN	UNI	UNE	SS	AFNOR	JIS
Nickel Chromium Steel		1.5680	12Ni19	2515						Z18N5	
		1.5710	36NiCr6	3135	640A35	111A				35NC6	SNC236
		1.5732	14NiCr10	3415			16NiCr11	15NiCr11		14NC11	SNC415(H)
		1.5752	14NiCr14	3415,3310	655M13 655A12	36A				12NC15	SNC815(H)
Nickel Chromium Molybdenum Steel		1.6511	36CrNiMo4	9840	816M40	110	38CrNiMo4(KB)	35CrNiMo4		40NCD3	
		1.6523	21NiCrMo2	8620	850M20	362	20NiCrMo2	20NiCrMo2		20NCD2	SNCM220(H)
		1.6546	40NiCrMo2	8740	311-Type7		40NiCrMo2(KB)	40NiCrMo2			SNC240
	40CrNiMoA	1.6582	34CrNiMo6	4340	817M40	24	35CrNiMo6(KB)		2503	35NCD6	
		1.6587	17CrNiMo6		820A16			14CrNiMo13		18NCD6	
Chromium Steel	15Cr	1.7015	15Cr3	5015	523M15				2541	12C3	SCr415(H)
	35Cr	1.7033	34Cr4	5132	530A32	18B	34Cr4(KB)	35Cr4		32C4	SCr430(H)
	40Cr	1.7035	41Cr4	5140	530M40	18	41Cr4	42Cr4		42C4	SCr440(H)
	40Cr	1.7045	42Cr4	5140				42Cr4	2245		SCr440
Manganese Steel	18CrMn	1.7131	16MnCr15	5155	527M20		16MnCr15	16MnCr15	2511	16MC5	
	20CrMn	1.7176	55Cr3	5115	527A60	48				55C3	SUP9(A)
	30CrMn	1.7218	25CrMo4	4130	1717CDS110		25CrMo4(KB)	55Cr3	2225	25CD4	SCM420 SCM430
	35CrMo	1.722	34CrMo4	4137,4135	708A37	19B	35CrMo4	34CrMo4	2234	35CD4	SCM432 SCRRM3
	40CrMoA	1.7223	41CrMo4	4140,4142	708M40	19A	41CrMo4	41CrMo4	2244	42CD4TS	SCM440
	42CrMo, 42CrMnMo	1.7225	42CrMo4	4140	708M40	19A	42CrMo4	42CrMo4	2244	42CD4	SCM440(H)
		1.7262	15CrMo5					12CrMo4	2216	12CD4	SCM415(H)
Chromium Steel		1.7335	13CrMo44	ASTM A182 F11 F12	1501-620Cr.27		14CrMo44	14CrMo45		15CD3.5 15CD4.5	
		1.7361	32CrMo12		722M24	40B	32CrMo12	F.124.A	2240	30CD12	
		1.738	10CrMo910	ASTM A182 F22	1501-622Cr.31;45		12CrMo9,10	TU.H	2218	12CD9;10	
		1.7715	14MoV63		1503-660-440			13MoCrV6			
	50CrVA	1.8159	50CrV4	6150	735A50	47	50CrV4	51CrV4	2230	50CV4	SUP10
		1.8509	41CrAlMo7		905M39	41B	41CrAlMo7	41CrAlMo7	2940	40CAD6,12	
		1.8523	39CrMoV139		897M39	40C	36CrMoV12				

### Material Comparison Table

#### Steel

ISO	Nations And Standard													
	GB(P)	W-nr	DIN	AISI/SAE	BS	EN	UNI	UNE	SS	AFNOR	JIS			
Steel	T10	1.1545	C105w1	W.110						C80KU C100KU	F515 F.516	1880	Y1105	
	T12A	1.1663	C125W	W.112						C120KU	(C120)		Y2120 SK2	
	crv,9sicr	1.2067	100cr6	L3	BL3						100Cr6		Y100C6	
	Cr12	1.208	X210Cr12	D3	BD3					X210Cr13KU 250Cr12KU	X210Cr12		Z200Cr12 SKD1	
	4Cr5MovSi	1.2344	X40CrMov51	H13	BH13						X40CrMoV5	2242	Z40CDV5 SKD61	
	cr6wV	1.2363	X100CrMoV51	A2	BA2					X35CrMoV05KU X40CrMoV51KU	X100CrMoV5	2260	Z100CDV5 SKD12	
	crWMo	1.2419	105wCr6							X100CrMoV51KU	105WCr5	2140	105WC13 SKS31 SKS2 SKS3	
	cr12w	1.2436	X210CrW12							10WCr6 107WCr5KU	X210CrW12	2312	SKD2	
	5CrNiMo	1.2542	45WCrV7	S1	BS1					X215CrW121KU	45WCrSi8	2710		
	3Cr2wBV	1.2581	X30WCrV93 X30WcrV93KU	H21	BH21					45WCrV8KU	X30WcrV9		Z30WCrV9 SKD5	
	Cr12Mov	1.2601	X165CrMov12							X28W09Ku X30WCrV93KU	X160CrMoV12	2310	SKD11	
	5CrNiMo	1.2731	55NiCrMoV6	L6						X165CrMoV12KU	F.250.S		55NCDV7 SKT4S	
	V	1.2833	100V1	W210	BW2								Y1105V KS43	
	W6Mo5Cr4V2Co5	1.3243	S6-5-2-5								HS6-5-2-5	2723	Z85WDCV SKH55	
	W18Cr4VCo5	1.3255	S18-1-2-5	T4	BT4						HS6-5-2-5	HS18-1-1-5		Z80WKC 10-05-04-1 SKH3
	w6Mo5Cr4V2	1.3343	S6-5-2S	M2	BM2						X78WCo1805KU	HS6-5-2	2722	Z85WDCV 06-05-04-02 SKH9
		1.3348	S2-9-2	M7					Z		X82WMo0605KU	HS-2-9-2	2782	Z100WCWV 09-02-04-02
	w18Cr4v	1.3355	S18-0-1	T1	BT1						HS2-9-2	HS18-0-1		Z80WCV 18-04-01 SKH2
	W6Mo5Cr4v3		S6-5-3	M3							X75W18KU			SKH52
				M42	BM42									SKH59

### Material Comparison Table

#### Steel

ISO	Nations And Standard					
	CHN	GER	JPN	JPN	USA	
	GB(P)	W-nr	DIN	JIS	DAIDO	AISI/SAE
Die Steel	<b>Plastic Molding Steel</b>					
					PX5N	P20mod
					NAK55	
					NAK80	
	3Cr13			SUS420J2mod	S-STAR	420mod
	<b>Cold Working Molding Steel</b>					
				SKS93	YK30	2
	9CrWMn			SKS3mod	GOA	01mod
	Cr12MoV	X165CrMoV12		SKD11	DC11	D2
				SKD11mod	DC53	D2mod
	<b>Hot Working Molding Steel</b>					
	4Cr5MoSiV1	X40CrMoV51		SKD61	DHA1	H13
					DH21	
					DH31-S	
					DH2F	

### Material Comparison Table

#### Stainless Steel

ISO	Nations And Standard											
	CHN	GER	USA	GBR	IT	ES	SE	FR	JPN			
	GB(P)	W-nr	DIN	AISI/SAE	BS	EN	UNI	UNE	SS	AFNOR	JIS	
Stainless Steel	0Cr13;1Cr12	1.4000	X6Cr13	403	403S17		X6Cr13	F3110	2301	Z6C13	SUS403	
		1.4001	X7Cr14					F8401				
	1Cr13	1.4006	X10Cr13	410	410S21	56A60	X12Cr13	F3401	2302	Z10C14	SUS410	
	1Cr17	1.4016	X6Cr17	430	430S15	56B;56C	X8Cr17	F3113	220	Z8C17	SUS430	
	2Cr13	1.4021	X20Cr13	410	S62	56B	X20C13	F3401		Z20C13	SUS410	
		1.4027	G-X20Cr14		420C29	56D				Z20C13M	SCS2	
	4Cr13	1.4034	X46Cr13		420S45	57	X40Cr14	F3405	2304	Z40CM;Z38C13M	SUS420J2	
	1Cr17Ni2	1.4057	X20CrNi172	431	431S29		X16CrNi16	F3427	2321	Z15CNi6.02	SUS431	
	Y1Cr17	1.4104	X12CrMoS17	430F			X10CrS17	F3117	2383	Z10CF17	SUS430F	
	1Cr17Mo	1.4113	X6CrMo171	434	434S17		X8CrMo17		2325	Z8CD17.01	SUS434	
		1.4313	X5CrNi134		425C11					Z4CND13.4M	SCS5	
		1.4408	G-X6CrNiMo1810		316C16			F8414			SCS14	
	4Cr9Si2	1.4718	X45CrSi93	HW3	401S45	52	X45CrSi8	F322		Z45CS9	SUH1	
	0Cr13Al	1.4724	X10CrAl13	405	403S17		X10CrAl12	F311		Z10C13	SUS405	
	Cr17	1.4742	X10CrAl18	430	430S15	60	X8Cr17	F3113		Z10CAS18	SUS430	
	8Cr20Si2Ni	1.4757	X80CrNiSi20	HNV6	443S65	59	X80CrSiNi20	F320V		Z80CSN20.02	SUH4	
	2Cr25N	1.4762	X10CrAl24	446			X16Cr26		2332	Z10CAS24	SUH446	
	Stainless Steel	0Cr18Ni9	1.4301	X5CrNi1810	304	304S15	58E	X5CrNi1810	F3551 F354 F3504	2332	Z6CN18.09	SUS304
		1Cr18Ni9MoZr	1.4305	X10CrNiS189	303	303S21	58M	X10CrNiS18.09	F3508	2346	Z10CNF18.09	SUS303
		0Cr19Ni10	1.4306	X2CrNi1911	304L	304S12		X2CrNi18.11	F3503	2352	Z2CN18.10	SCS19
			1.4308	G-X6CrNi189		304C15					Z6CN18.10M	SCS13
		Cr17Ni7	1.4310	X12CrNi177	301			X12CrNi1707	F3517	2331	Z12CN17.07	SUS301
			1.4311	X2CrNi1810	304LN	304S62				2371	Z2CN18.10	SUS304LN
		0Cr19Ni9	1.4350	X5CrNi189	304	304S31	58E	X5CrNi1810			Z6CN18.09	SUS304
		0Cr17Ni11Mo2	1.4401	X5CrNiMo1712	316	316S16	Z6CND17.11	X5CrNiMo1712	F3543	2347	1.4401	SUS316
00Cr17Ni13Mo2		1.4429	X2CrNiMo17133	316LN					2375	Z2CND17.13	SUS316LN	
oCr27Ni12Mo3		1.4435	X2CrNiMo18143	316L	316S12		X2CrNiMo1713		2353	Z2CDN17.13	SCS16	
00Cr19Ni13Mo3		1.4438	X2CrNiMo17133	317L	317S12		X2CrNiMo18.16		2367	Z2CND19.15	SUS317L	
		1.4460	X8CrNiMo275	329L					2324		SUS329L;SCH11;SCS11	
1Cr18Ni9Ti		1.4541	X6CrNiTi1810	321	2337	321S12	X6CrNiTi1811	F3553	58B	Z6CNT18.10	SUS321	
1Cr18Ni11Nb		1.4550	X6CrNiNb1810	347	347S17	58F	X6CrNiTi1811	F3552	2338	Z6CNNb18.1	SUS347	
Cr18Ni12Mo2Ti		1.4571	X6CrNiMoTi17122	316Ti	320S17	58J	X6CrNiMoTi17	F3535	2350	Z6NDT17.12		
Stainless Steel		1.4581	G-X5CrNiMoNb1810		318C7		XG8CrNiMo18			Z4CNDNb1812M		
	Cr17Ni12Mo3Nb	1.4583	X10CrNiMoNb1812	318			X6CrNiMoTiNb17			Z6CNDNb1713B	SCS22	
	1Cr23Ni13	1.4828	X15CrNiSi2012	309	309S24					Z15CNS20.1	SUH309	
	0Cr25Ni20	1.4845	X12CrNi2521	310S	310S24		X6CrNi2520	F331	2361	Z12CN2520	SUH310	
	Cr15Ni36W3Ti	1.4864	X12NiCrSi3616	330						Z12CN35.1	SUH330	
		1.4865	G-X40NiCrSi3818		330C11		XG50NiCr3919				SCH15	
	5Cr2Mn9Ni4N	1.4871	X53CrMnNiN219	EV8	349S54;321S12	58B	X53CrMnNiN219			Z52CMN21.0	SUH35	
	1Cr18Ni9Ti	1.4878	X12CrNiTi189	321	321S320	58C	X6CrNiTi1811	F3523		Z6CNT18.12	SU321	

### Material Comparison Table

#### Cast Iron

ISO	Nations And Standard										
	CHN	GER	USA	GBR	IT	ES	SE	FR	JPN		
	GB(P)	W-nr	DIN	AISI/SAE	BS	EN	UNI	UNE	SS	AFNOR	JIS
Nodular Iron	QT400-18	GGG40	60-40-18	400/17	GS370-17	FGE38-17	0717-02	FGS370-17	FCD400		
	QT450-10		65-45-12	420/12	GS400-13	FGE42-12		FGS400-12	FCD450		
	QT500-7	GGG50	70-50-05	500/7	GS500-7	FGE50-7	0727-02	FGS500-7	FCD500		
	QT600-3	GGG60	80-60-03	600/7	GS600-2	FGE60-2	0732-03	FGS600-2	FCD600		
	QT700-2	GGG70	100-70-03	700/2	GS700-2	FGE70-2	0737-01	FGS700-2	FCD700		
	QT800-2	GGG80	120-90-02	800/2	GS800-2	FGE80-2	0864-03	FGS800-2	FCD800		
	QT900-2			900/2							
	Grey Cast Iron		GG40	NO.60				0140	FGL400	FC350	
HT350		GG35	NO.50	350	G35	FG35	0135	FGL350	FC300		
HT300		GG30	NO.45	300	G30	FG30	0130	FGL300	FC250		
HT250		GG25	NO.35	250	G25	FG25	0125	FGL250	FC200		
HT200		GG20	NO.30	200	G20	FG20	0120	FGL200	FC150		
HT150		GG15	NO.20	150	G15	FG15	0115	FGL150	FC100		
HT100				100	G10		0110				

### Hardness Comparison Table

Hardness				Tensile Strength
Rockwell Hardness (RH)		Vickers Hardness (VH)	Brinell Hardness (BH)	
HRC	HRA	HV	HB	
70.0	86.6	1037		
69.5	86.3	1017		
69.0	86.1	997		
68.5	85.8	978		
68.0	85.5	959		
67.5	85.2	941		
67.0	85.0	923		
66.5	84.7	906		
66.0	84.4	889		
65.5	84.1	872		
65.0	83.9	856		
64.5	83.6	840		
64.0	83.3	825		
63.5	83.1	810		
63.0	82.8	795		
62.5	82.5	780		
62.0	82.2	766		
61.5	82.0	752		
61.0	81.7	739		
60.5	81.4	726		
60.0	81.2	713		2555
59.5	80.9	700		2500
59.0	80.6	688		2450
58.5	80.3	676		2395
58.0	80.1	664		2345
57.5	79.8	653		2295
57.0	79.5	642		2250
56.5	79.3	631		2205
56.0	79.0	620		2160
55.5	78.7	609		2115
55.0	78.5	599		2075
54.5	78.2	589		2035
54.0	77.9	579		1995
53.5	77.7	570		1955
53.0	77.4	561		1920
52.5	77.1	551		1885
52.0	76.9	543		1850
51.5	76.6	534		1815

Hardness				Tensile Strength
Rockwell Hardness (RH)		Vickers Hardness (VH)	Brinell Hardness (BH)	
HRC	HRA	HV	HB	
51.0	76.3	501		1780
50.5	76.1	494		1750
50.0	75.8	488		1720
49.5	75.5	481		1690
49.0	75.3	474		1660
48.5	75.0	468		1630
48.0	74.7	461		1605
47.5	74.5	455		1575
47.0	74.2	449		1550
46.5	73.9	442		1525
46.0	73.7	436		1500
45.5	73.4	430		1475
45.0	73.2	424		1450
44.5	72.9	418		1430
44.0	72.6	413		1405
43.5	72.4	407		1385
43.0	72.1	401		1360
42.5	71.8	396		1340
42.0	71.6	391		1320
41.5	71.3	385		1300
41.0	71.1	380		1280
40.5	70.8	375		1260
40.0	70.5	370		1245
39.5	70.3	365		1225
39.0	70.0	360		1210
38.5		355		1190
38.0		350		1175
37.5		345		1160
37.0		341		1140
36.5		336		1125
36.0		332		1110
35.5		327		1095
35.0		323		1080
34.5		318		1065
34.0		314		1050
33.5		310		1035
33.0		306		1020
32.5		302		1010

## Hardness Comparison Table

Hardness				Tensile Strength
Rockwell Hardness (RH)		Vickers Hardness (VH)	Brinell Hardness (BH)	
HRC	HRA	HV	HB	
32.0		304	298	995
31.5		300	294	980
31.0		296	291	970
30.5		292	287	960
30.0		289	283	950
29.5		285	280	935
29.0		281	276	920
28.5		278	273	910
28.0		274	269	900
27.5		271	266	890
27.0		268	263	880
26.5		264	260	870
26.0		261	257	860
25.5		258	254	850
25.0		255	251	835
24.5		252	248	830

Hardness				Tensile Strength
Rockwell Hardness (RH)		Vickers Hardness (VH)	Brinell Hardness (BH)	
HRC	HRA	HV	HB	
24.0		249	245	820
23.5		246	242	810
23.0		243	240	800
22.5		240	237	790
22.0		237	234	785
21.5		234	232	775
21.0		231	229	765
20.5		229	227	760
20.0		226	225	750
19.5		223	222	745
19.0		221	220	735
18.5		218	218	730
18.0		216	216	725
17.5		214	214	715
17.0		211	211	710

## Certifications



ISO9001:2015

